

**6VPLE1/6VPLE1+**  
(VIA PLE-133 CHIPSET FOR  
PIII/ Celeron/ VIA CyrixIII CPUs)  
AT Form Factor  
Main Board

User' s Manual (ver.: 1.0)

## **Copyright**

Copyright© 2001 by this company. No part of this document may be reproduced, transmitted, transcribed, stored in a retrievable system, or translated into any natural or computer language, in any form or by any means without prior written permission. This manual and the information contained herein are protected by copyright. All rights reserved.

Manual version: 1.0  
Ref. No. 3053312  
Published in 2001

### **Warning and disclaimer**

This manual is designed to provide information about the Pentium® II/III main board. Every has effort have been made to make this manual as accurate as possible, but no warranty or fitness is implied. All the information is provided on an 'as is' basis. The author and his corresponding publishing company shall have neither liability nor responsibility to any person or entity with respect to any loss or damages arising from the information contained in this manual or from the use of the system board that accompanies it.

Information contained in this manual is subject to change without notice. The manufacturer of the system board will not be held responsible for technical or editorial omissions made herein, nor for the incidental or consequential damages resulting from its furnishing, performance, functionality or use. Subsequent changes to this manual will be incorporated into the next edition. We welcome any suggestion regarding this manual or our computer products.

### **Trademarks**

- Intel® and Pentium® are registered trademarks of Intel® Corporation.
- IBM® is a registered trademark of International Business Machines Corporation.
- Microsoft® is a registered trademark of Microsoft® Corporation.
- PCI® is a registered trademark of PCI® Special Interest Groups.
- AWARD® is a registered trademark of Award Software Inc.

All other trademarks are the property of their respective owners.

---

## Table of Contents

<b>Chapter 1</b>	<b>Introduction.....</b>	<b>1</b>
1-1	Main Board Overview.....	1
1-2	Specifications.....	3
1-3	Notice of Hardware Installation.....	5
1-4	Notice of CD Driver Installation.....	6
1-5	How to Install Software Driver.....	7
<b>Chapter 2</b>	<b>Installation.....</b>	<b>8</b>
2-1	Layout Reference.....	8
2-2	Jumper Setting.....	9
2-2-1	JP1-JP3:Audio/AMR Function Selector.....	9
2-2-2	JP5/JP7:CPU Type Selector.....	10
2-2-3	JBAT1:CMOS Status.....	11
2-3	Connectors .....	12
2-3-1	Front Panel.....	12
2-3-2	Back Panel.....	14
	COM1/COM2.....	14
	LPT1 (Parallel Port).....	15
	USB1/USB2(Universal Serial Bus).....	16
	AT Keyboard .....	17
	PS/2 Mouse.....	18
2-3-3	ATX Power Supply Connector.....	19
2-3-4	AT Power Supply Connector.....	20
2-3-5	J2 Connector.....	21
2-3-6	CPU Fan1 & Fan2 Connectors.....	22
2-3-7	Floppy1.....	23
2-3-8	IDE1 & IDE2.....	24
2-3-9	J1-Audio Connectors & Game port.....	25
2-3-10	VGA Connector.....	26

---

2-4	DIMM Memory Installation.....	27
Chapter 3 BIOS Setup.....		28
3-1	Award BIOS CMOS Setup.....	28
3-2	Standard CMOS Setup.....	28
3-3	BIOS Features Setup.....	30
3-4	Chipset Features Setup.....	35
3-5	Integrated Peripherals.....	39
3-6	Power Management Setup.....	45
3-7	PNP/PCI Configuration Setup.....	48
3-8	PC Health Status.....	50
3-9	Frequency/Voltage Control.....	52
3-10	Password Setting.....	53
3-11	Load Optimized Defaults.....	58
3-12	Save and Exit Setup.....	59
3-13	Quit Without Saving.....	60
Chapter 4 Appendix.....		61
4-1	Memory Map.....	61
4-2	I/O Map.....	62
4-3	Time & DMA Channels Map.....	63
4-4	Interrupt Map.....	64
4-5	RTC & CMOS RAM Map.....	65
4-6	ISA I/O Address Map.....	66
Chapter 5 Q & A.....		68
5-1	Error Messages During Power On Self Test.....	68

---

# Chapter 1 Introduction

## 1-1 Main Board Overview

The main board's design is based on VIA chipset, "VT8601A & VT82C686A (PLE-133 Chipset)," which provides a high-performance/desktop solution to the Intel® FC-PGA(or PPGA) Celeron/ PentiumIII & VIA Cyrix® III Processors. The integrated H/W 3D VGAcontroller adopts 64-bit 133MHz host bus speed and shares 4MB or 8MB from frame buffer memory with system which improves the performance eminently.

The main board integrates PCI-mastering dual full-duplex direct-sound AC97-link-compatible sound system. Hardware soundblaster-pro and hardware-assisted FM blocks are included for Windows DOS box and real-mode DOS compatibility. Loopback capability is also implemented for directing mixed audio stream into USB and 1394 speaker for high quality digital audio.

The main board also implements high performance I/O Controller utilizing with fully Plug and Play device which supports 2.88 MB Floppy, Dual 16550 Compatible (with 16 bytes FIFO, up to 460K baud rate) Serial Port, ECP (Enhanced Capabilities Port), EPP (Enhanced Parallel Port) parallel port, Infrared IrDA (HPSIR), and Amplitude Shift Keyed IR. (ASKIR) port.

---

The main board supports four 32-bit PCI & one 16-bit ISA for highest performance I/O add-on adapter cards. The system board supports 4 PCI bus-mastering slots (PCI 2.2 compliant) and allows synchronous CPU and PCI bus clock frequency. These are also key benefits in PC operation, new system setup and power conservation.

In conclusion, the main board is a combination of the highest in performance, flexibility, efficiency, and ease of use that meets a variety of price/performance levels. The main board is an ideal platform for the increasing requirements of today's and future's desktop application.



*“6VPLE1” Comes with VIA 82C686A south bridge chipset which provides IDE ATA-66 HDD port. “6VPLE1+” has VIA 82C686B provides ATA-100 interface.*

---

## 1-2 Specifications

- **PCB board size:** 22 cm x 23.5 cm
- **PCB layer:** 4 layers
- **Socket 370**  
Support Intel® Pentium III™ and Socket-370 Celeron™, VIA Cyrix® III processors, 66/100/133 MHZ FSB & PC-133 memory.



*CPU is not enclosed in the package.*

- **Chipset :** VIA VT8601A & VIA VT82C686A (PLE-133 Chipset)
- **Memory DIMM :** 2 of 168-pin 3.3V DIMM(not support EDO RAM), supports to PC-133 specification.
- **Expansion Slot :** 4 x PCI slots, 1x ISA slot, 1x AMR slot
- **Audio/Sound Function**  
Hardware controller → AC97-link-compatible sound system
- **Video/Graphics Function**
  - Shared system memory area 4MB, or 8MB (default)
  - 32-bit true color



*User MUST use the onboard VGA function that is unable to be disabled. Other graphic cards are not acceptable.*

- **BIOS:** flash ROM BIOS  
Award® full **PnP** (Plug & Play) BIOS



---

● **I/O function**

- 2 x PCI IDE devices
- 1 x FDC, 2 x serial ports(16550 fast COM.)
- 1x parallel port device /EPP/ECP/SPP
- 2x USB connectors optional
- IrDA (infrared) connector

- **AT form factor:** AT/ATX power supply optional

- **Green function :** Complied with APM (Advanced Power Management)

- **Special features**

- Windows power off (ATX power supply required)



*USB Connector is an optional item.*



*This main board has been built with AC-97 sound & on-chip VGA functions already, if user needs Modem function, this main board allows either AMR slot type "MR MODEM" or PCI Internal modem. If user needs LAN networking function, please choose PCI internal LAN card.*

---

## 1-3 Notice of Hardware Installation

Before hardware installation, make sure you have checked the following things.

### **A. Check the package**

If any of these items is missing or damaged, contact the dealer from whom you purchase. Leave this main board in its original package until you are ready to install it. In the package, there are:

- the main board
- manual
- cables
- driver & utility / CD

### **B. Make sure power is off.**

During hardware installation, be sure that there is no power connected during this period.

### **C. Avoid ESD (Electrical Static Discharge).**

While installing the main board, wear a grounded wristband or ankle strap to avoid ESD (Electrical Static Discharge).

---

## 1-4 Notice of CD Driver Installation

This CD contains below drivers. The user must read “Index” (HTML format) before installing required drivers. Index offers all the information on all the drivers.

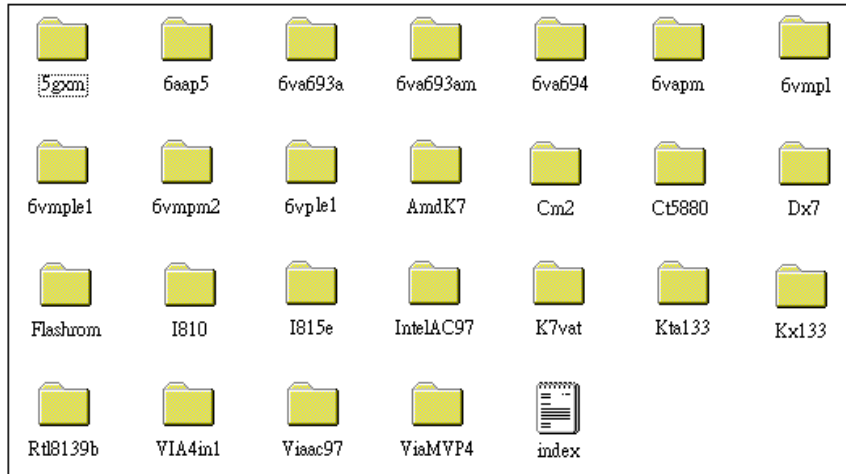

*CD driver is always updated with the latest version, so the actual CD content may be somewhat different from the above picture.*

1. **Main boards:** 5gxm, 6aap5, 6va693a, 6va693am, 6va694, 6vapm, 6vmp1, 6vmp1e1, 6vmp2, 6vple1, Amdk7, I810, I815e, K7vat, Kta133, Kx133, ViaMVP4 (**please choose 6vple1 directory for this main board**).
2. **DX7:**windows DirectX7 driver.(for 3D game.....)
3. **Flashrom:**BIOS flash upgrade utility.

---

## 1-5 How to Install Software Driver

### 1. Install “Via 4 in 1” :

Select “**VIA 4 in 1**” directory from attached CD, then click “**setup**” to complete the installation; the “**Via 4 in 1**” drive provides O.S. like windows 98/ ME to recognize VIA Chipset.

### 2. Install sound drive:

Select “**Viaac97**” from attached CD, the chick “**setup**” to complete the installation. This driver provides AC-97 Sound driver for O.S. like windows 9X, for windows-ME & win-2000 can detect by themselves.

### 3. Install VGA display driver:

Select “**6vmp1e1**” to specify your O.S. like windows9X/ ME/ 2000 to complete it.

4. If user wants to update BIOS, please chooses “**Flashrom**” utility.

---

## Chapter 2 Installation

### 2-1 Layout Reference

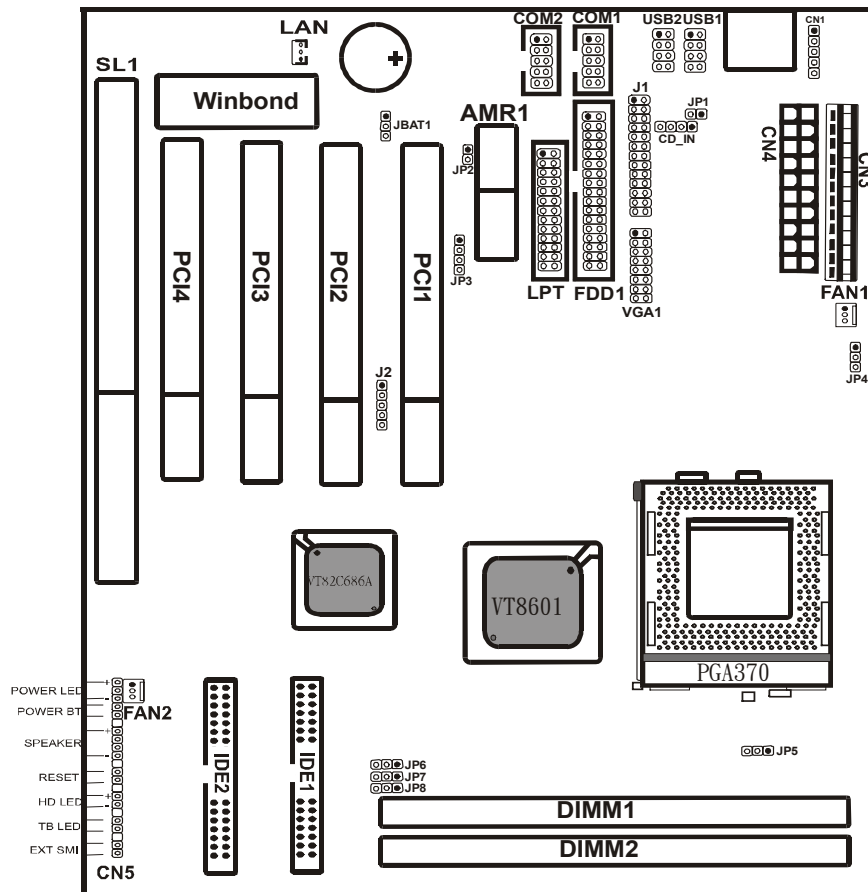

---

## 2-2 Jumper Settings

### 2-2-1 JP1 – JP3 : Audio/AMR Function Selector

JP1/JP2 are 2-pin selectors. JP3 is a 4-pin selector. Please select the right functions as below.

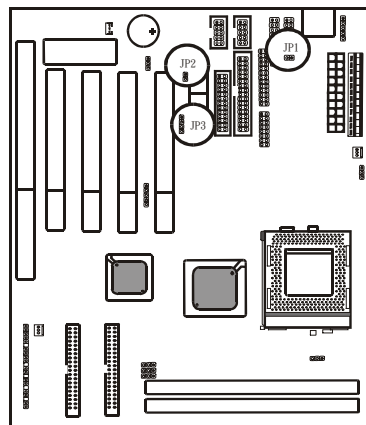

JP1-JP3: Audio/AMR Function Selector



	AC97	AC97+MC97	AMR
<b>JP1</b>	ON	ON	OFF
<b>JP3</b>	1-2	1-2,3-4	3-4
	On board Audio only	On board Audio and AMR	On board Audio disable use AMR slot

<b>JP2</b>	ON	Secondary CODEC for AMR(default)
	OFF	Primary CODEC for AMR

 Please don't change default setting.

---

## 2-2-2 JP5/JP7 : CPU Type Selector

**JP5/JP7** are 3-pin connectors which provide to select CPU type. Please select the right CPU type as below.

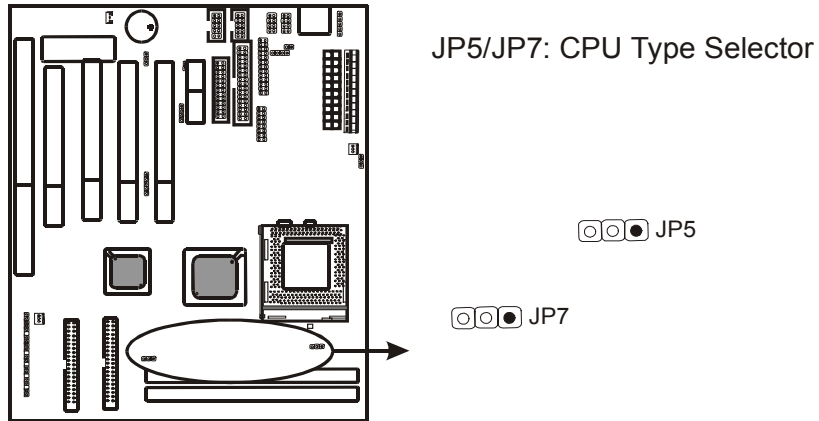

CPU Type	JP5	JP7
Celeron CPU	1-2	2-3
Celeron-100 CPU	1-2	2-3
Intel PIII CPU	2-3	2-3
Cyrix III CPU	1-2	2-3

---

### 2-2-3 JBAT1: CMOS Status

**JBAT1** is a 3-pin connector. Clear CMOS if system password is forgotten. Below are details to show how to clear CMOS.

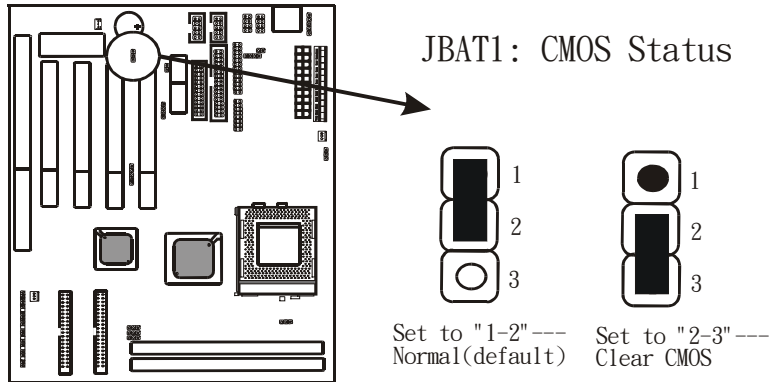

#### Procedure to clear CMOS:

- Step 1: Shut down the system and disconnect the power supply from AC power.
- Step 2: Pull out the power cable from ATX connector "POWER1".
- Step 3: Short the CMOS jumper by putting jumper cap on Pin 2-3 for a few seconds.
- Step 4: Return to pin 1-2 for normal setup.
- Step 5: Link ATX power cable to ATX connector & connect AC power to power supply.
- Step 6: Turn on system power.



*If you'd like to set password, press "DEL" Key during system bootup to enter CMOS setup and establish a new password.*



---

## 2-3 Connectors

There are many connectors on this main board. Refer to the following pages for details.

### 2-3-1 Front Panel

*Front panel* has connectors as “PW-LED,” “PW-BT,” “SPEAKER,” “RESET,” “HD-LED,” “TB-LED,” and “EXTSMI.” Please refer the details as below.

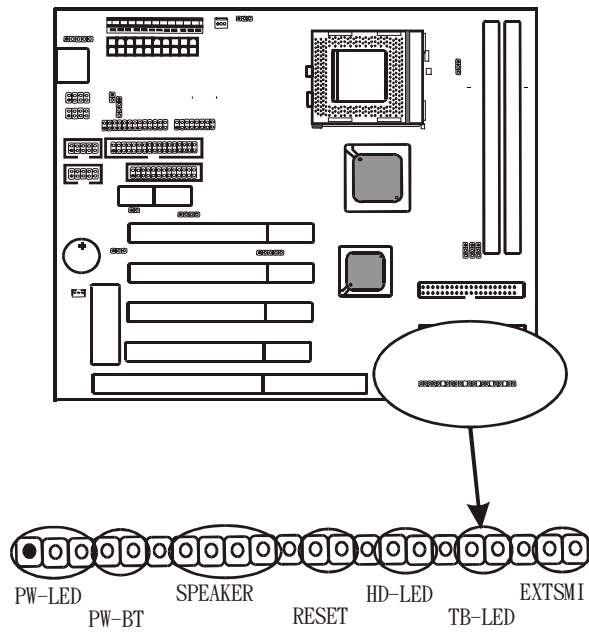

---

**PW-LED** is a 3-pin connector. It is used to connect to the LED on the case front panel. The LED shows the status of the power.

**PW-BT** with a 2-pin Berg strip on case front panel indicates the current power status of system. It is used to connect to the Power Button on the front panel of the case (if there is).

**SPEAKER** is a 4-pin keyed Berg strip. It is used to connect to the case speaker to the main board for sound purpose.

**RESET connector** is a 2-pin keyed Berg strip, connected to the push button reset switch on the case front panel. Shorting both pin 1 & pin 2 can reset the system, which is similar to the power off and then on again.

**HD-LED** (Hard Disk activity LED connector) is a 2-pin keyed Berg strip. It is used to connect to front panel Hard Disk LED.

**TB-LED** with a 2-pin keyed Berg strip on case front panel indicates the current speed status of system.

**EXTSMI** is a 2-pin keyed Berg strip, which is also called “green” or “sleep” connector. When SMI is turned from open to close and back to open, the system will enter sleep mode immediately. This function is to make sure power saving is working well. In PC system, it is used to connect to the push button SMI switch located on the case front panel (if there is). The system can be forced to power saving mode by pressing the SMI switch.

---

## 2-3-2 Back Panel

There are COM1/ COM2, LPT, USB1/USB2 and AT keyboard, PS/2 mouse on case back panel. Please refer to more details as below.

### COM1/COM2

*The onboard serial port 1 and port 2* are the 9-pin D-subminiature male connector **COM1** and **COM2**. COM1 and COM2 can be disabled in BIOS setup. Please refer to Chapter 3 “Integrated Peripherals” for more information.

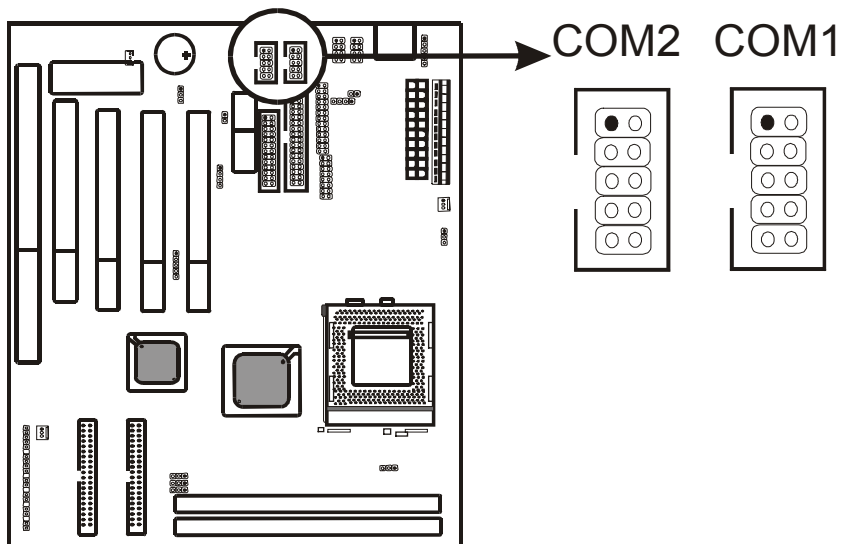

---

## LPT

*The onboard parallel port* is a 25-pin female connector, marked as “LPT.”

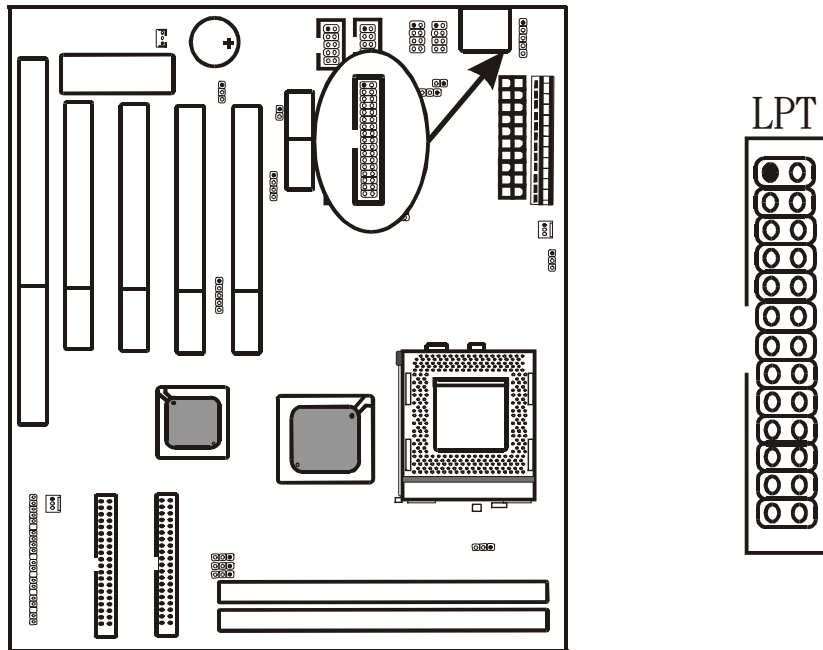

---

## USB1/USB2 (Universal Serial Bus)

*Universal Serial Bus connector*, marked “USB,” is used to connect USB devices. There are 4 USB connectors on this main board.

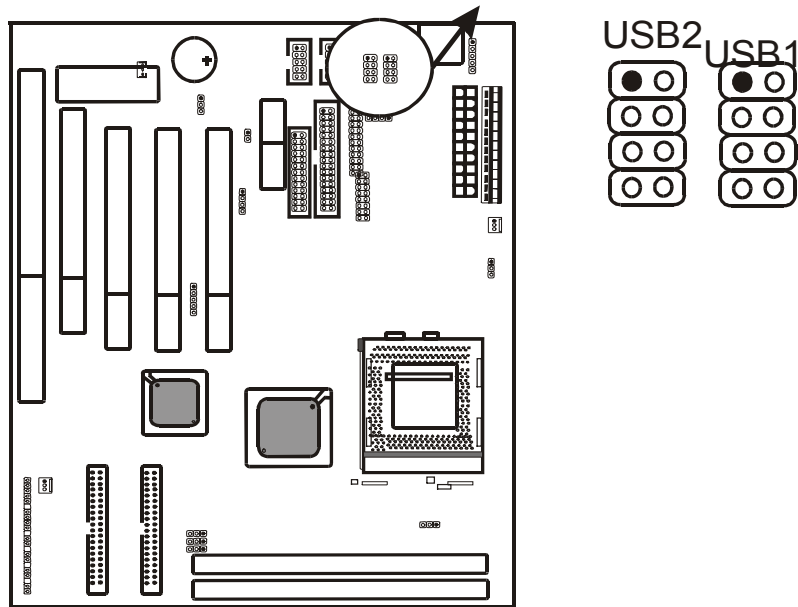

*Note: USB cables are optional items.*

---

## AT Keyboard

AT keyboard is a 5-pin connector.

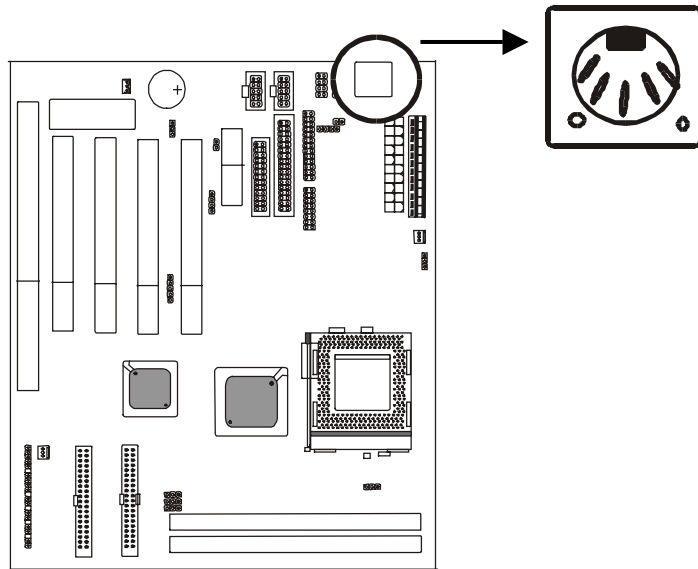

---

## PS/2 Mouse

PS/2 Mouse is a 5-pin connector to connect to mouse connector.

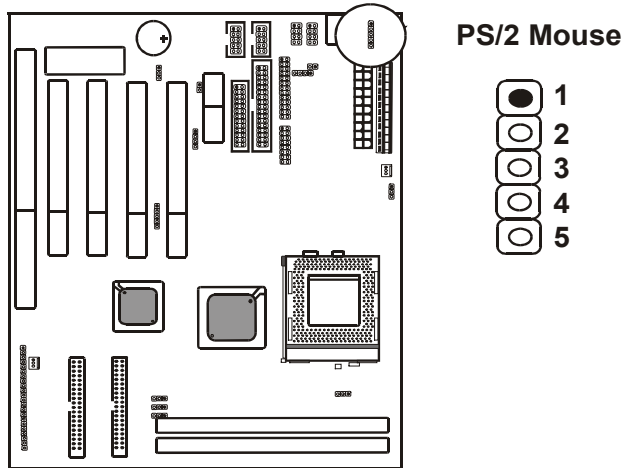

---

### 2-3-3 ATX Power Supply Connector

The main board supports standard AT and ATX power supply. *ATX power supply connector* has 20 pins, which is especially designed for ATX case. The ATX power supply supports the function of the “**Soft Power On Momentary switch**” which connects the front panel switch to the 2-pin **SOFT-PWR** on the system board. While the power switch on the back of ATX power is turned on, the full power will not go into the system board until the front panel switch is momentarily pressed. Push the switch again to turn off the power to the system board.

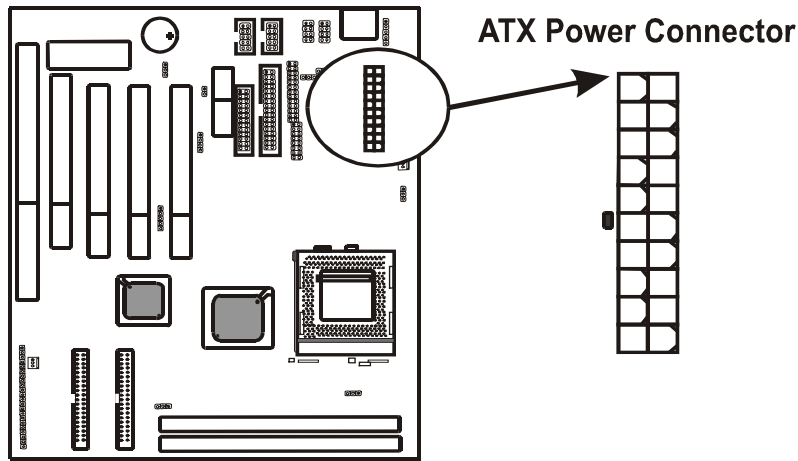

20	19	18	17	16	15	14	13	12	11
5V	5V	-5V	GND	GND	GND	PS-ON	GND	-12V	3.3V
12V	5V-SB	PW-OK	GND	5V	GND	5V	GND	3.3V	3.3V
10	9	8	7	6	5	4	3	2	1



---

### 2-3-4 AT Power Supply Connector

The main board supports standard AT and ATX power supply. AT Power supply has 12 pins.

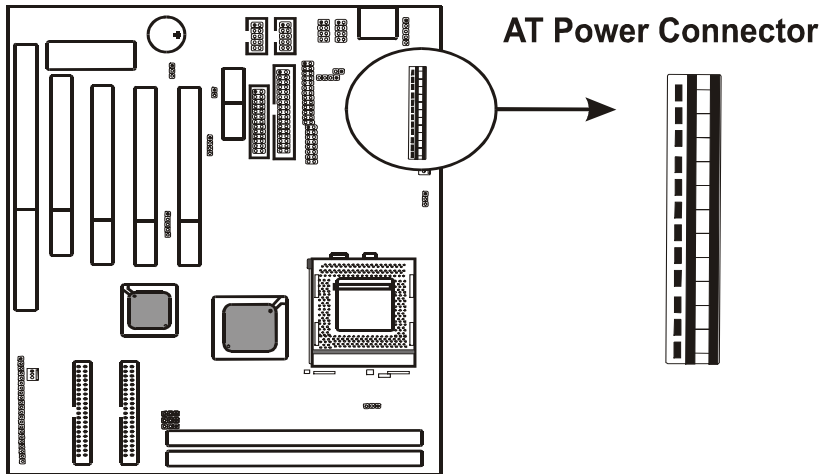

Pin	Signal	Pin	Signal
1	POWER GOOD	7	GROUND
2	+5V DC	8	GROUND
3	+12V DC	9	-5V DC
4	-12V	10	+5V DC
5	GROUND	11	+5V DC
6	GROUND	12	+5V DC

### 2-3-5 J2 Connector

---

**J2 connector** supports wireless infrared module. With this module and application software like LAPlink, or WIN95 Direct Cable Connection, user can transfer data to or from laptops, notebooks, PDA and printers. This connector supports **HPSIR**, **ASKIR**, and **Fast IR**.

Attach Infrared module to IR connector and enable BIOS “Infrared function.” Be sure to put in the right direction during installation.

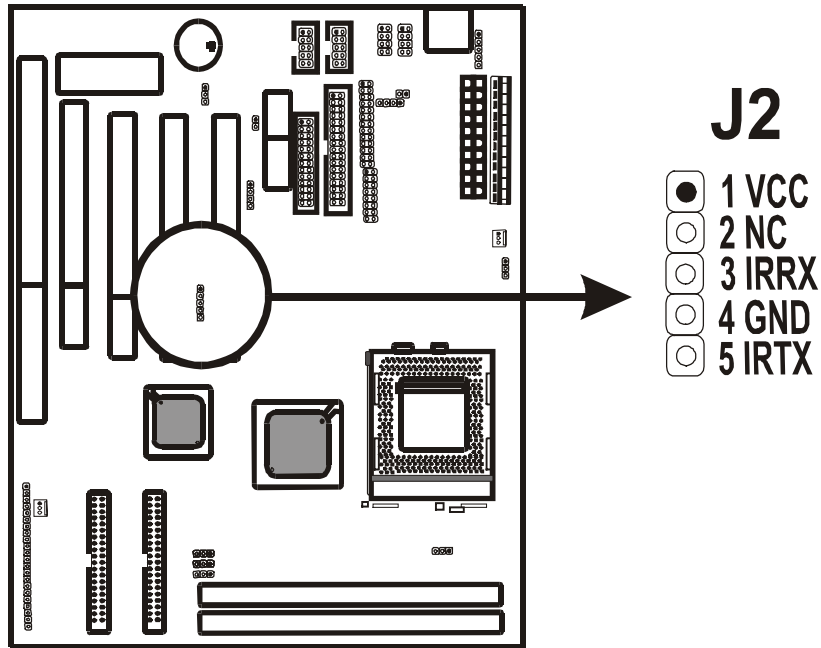

---

### 2-3-6 CPU FAN1 & FAN2 Connectors

CPU fan is a 3-pin connector, and the main board supports 2 FAN connectors. As the main board supports hardware monitoring, the system can detect fan speed automatically. The user may refer to Chapter 3 “3-4 Chipset Features Setup” to see the CPU fan speed.

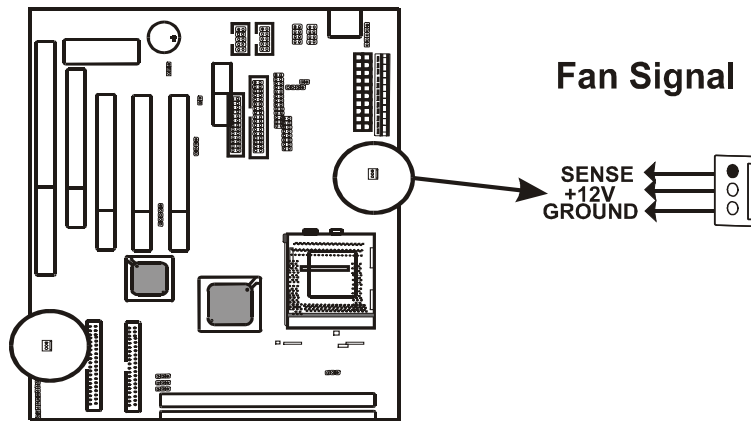

---

### 2-3-7 FLOPPY1

*FLOPPY1* has 34 pins and is used to attach the floppy drive cable.

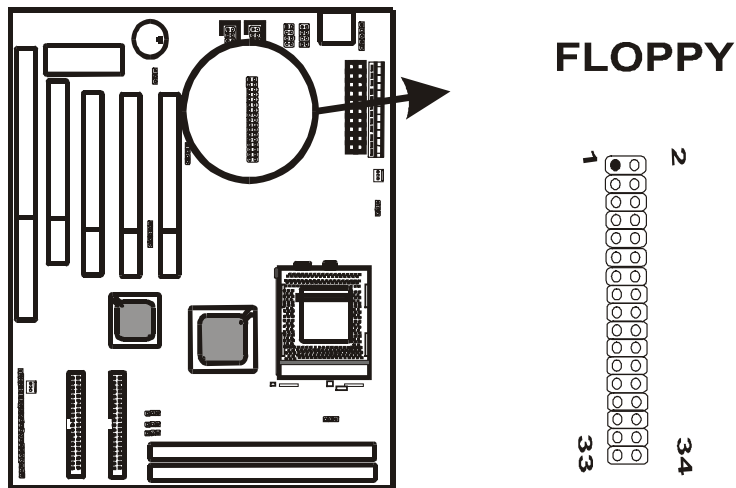

---

### 2-3-8 IDE1 and IDE2

The main board supports 2 IDE connectors: IDE1 and IDE2. IDE connectors have 40 pins. IDE1 is the primary channel, and IDE2 is the secondary. Each channel supports 2 IDE devices, and 4 channels in total for this main board.

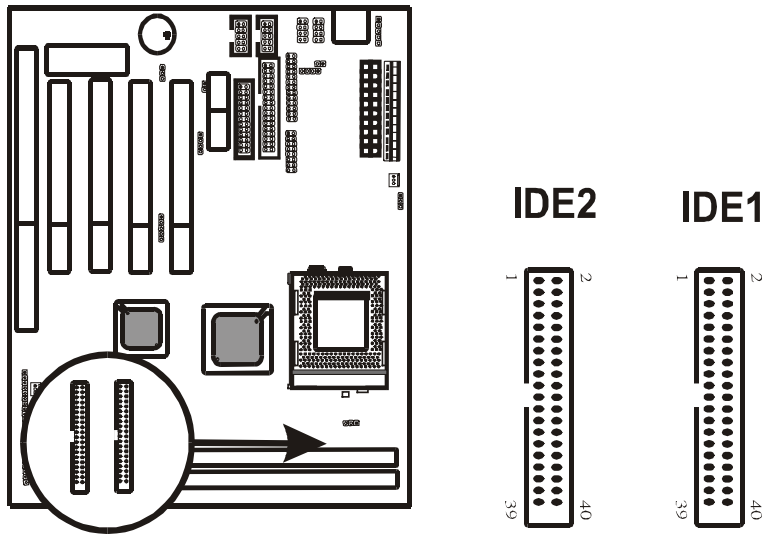

---

### 2-3-9 J1 - Audio Connectors & Game Port

J1 is a 26-pin connector connecting to the enclosed cable for Game, MIC, Line-in, Line-out.

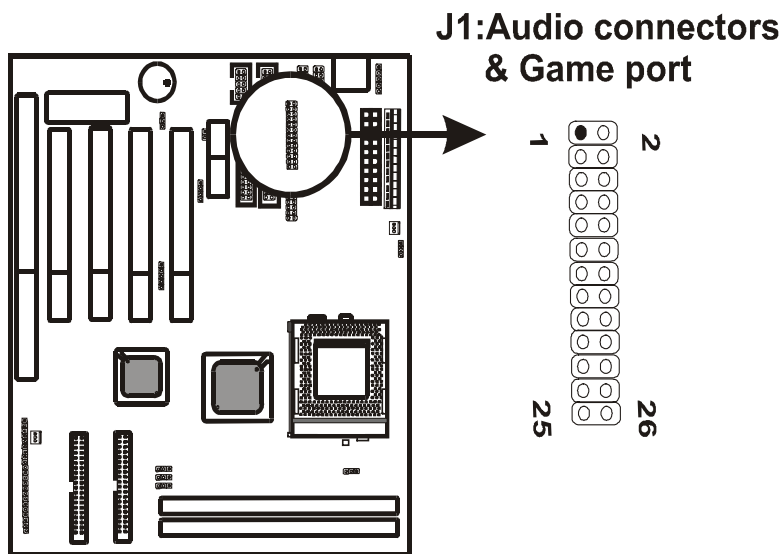

---

### 2-3-10 VGA Connector

VGA connector is a 16-pin connector providing video functions. In the package, there is a back panel VGA cable connecting to this connector.

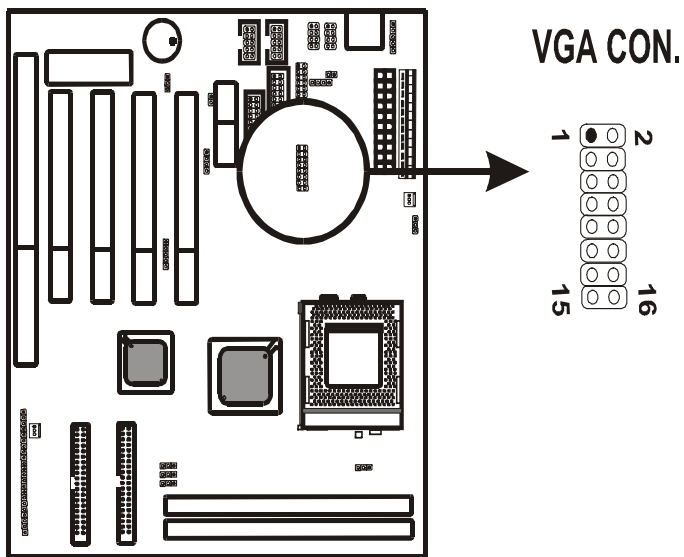

---

## 2-4 DIMM Memory Installation

The main board has 2 DIMMs on board. Chipset can support maximum memory up to 512M Bytes. Insert the module as shown. Due to different number of pins on either side of the breaks, the module will only fit in the orientation as shown.

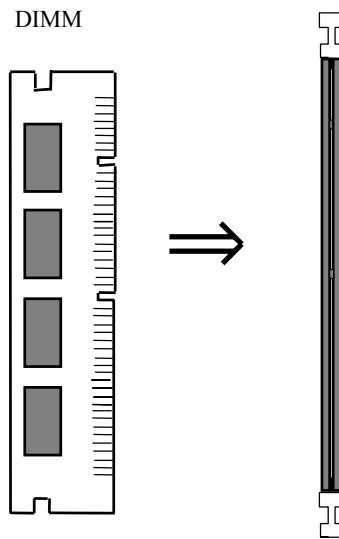

*Chipset SUPPORTS SDRAM.*



*With 100 MHz CPUs like PII/PIII, Cyrix III, the system **MUST** be installed with PC-100, 100MHz SDRAM module.*



---

## Chapter 3 BIOS Setup

### 3-1 Award BIOS CMOS Setup

The menu displays all the major selection items and allows user to select any of shown item. The selection is made by moving cursor (press any direction key ) to the item and press <Enter> key. An on-line help message is displayed at the bottom of the screen as cursor moves to various items which provides user better understanding of each function. When a selection is made, the menu of the selected item will appear. So the user can modify associated configuration parameters.



---

## 3-2 Standard CMOS Setup

The "Standard CMOS Setup" allows user to configure system setting such as **current date** and **time**, **type of hard disk drive** installed in the system, **floppy drive type**, and the type of **display monitor**. Memory size is auto detected by the BIOS and displayed for your reference. When a field is highlighted (direction keys to move cursor and <Enter> key to select). The entries in the field will be changed by pressing <PageDown> or <PageUp> key or user can enter new data directly from the keyboard.

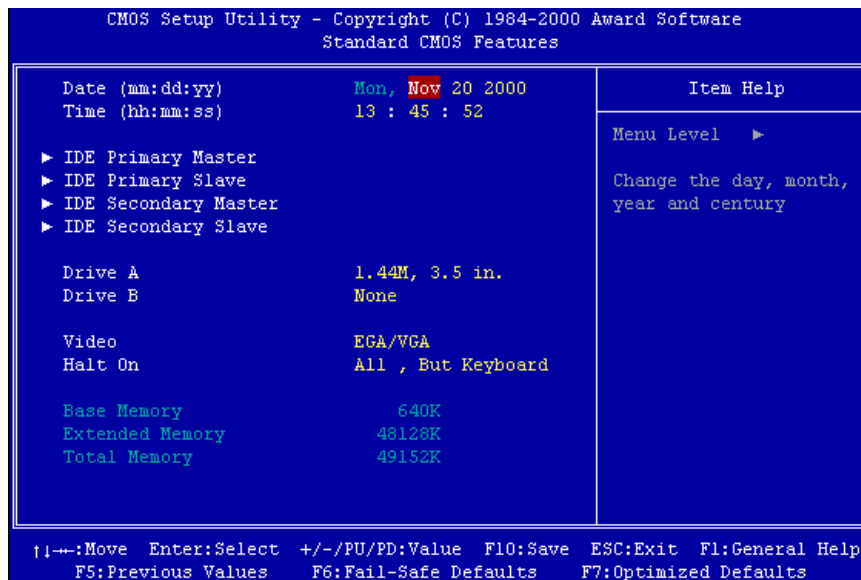

### 3-3 BIOS Features Setup

Menu below shows all of the manufacturer's default values of this main board. Move the cursor by pressing direction keys and <PageDown> or <PageUp> key to modify the parameters, pressing [F1] key to display help message of the selected item. This setup program also provide 2 convenient ways to load the default parameter data from BIOS [F6] or CMOS [F7] area if shown data is corrupted. This provides the system a capability to recover from any possible error.

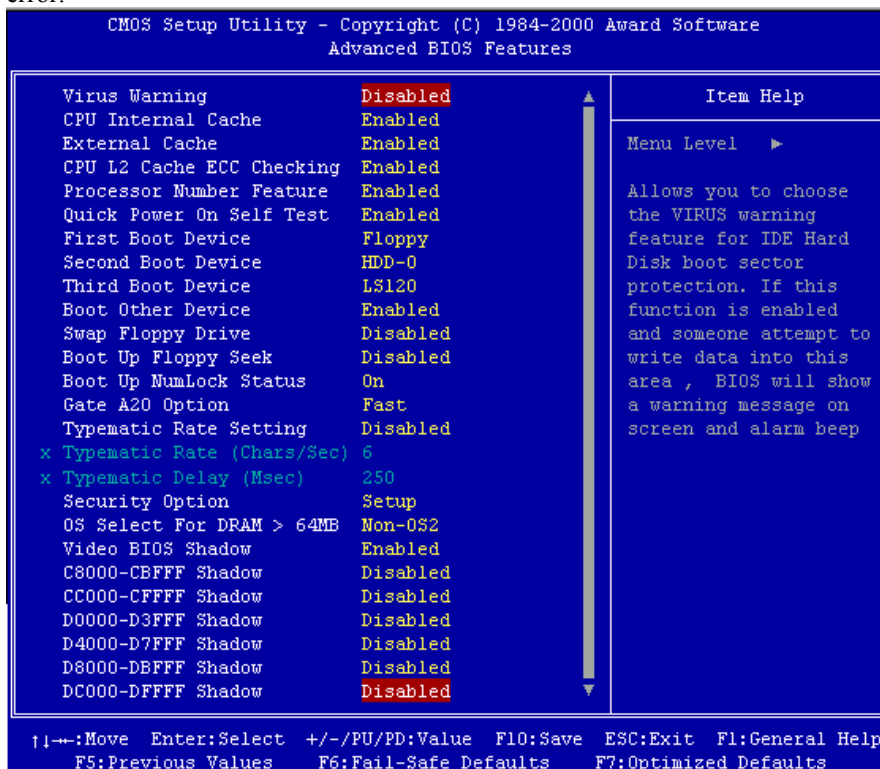

---

***Virus Warning***

**:Enabled**

**:Disabled** (default)

***CPU Internal Cache***

**:Enabled** (default): enable L1 cache

**:Disabled:** disable L1 cache

***External Cache***

**:Enabled**(default)

**:Disabled**

***CPU L2 Cache ECC Checking***

**:Enabled**(default)

**:Disabled**

***Processor Number Feature***

**:Enabled**(default)

**:Disabled**

***Quick Power On Self Test***

This category speeds up power on self test.

**:Enabled** (default): BIOS will shorten or skip some check items.

**:Disabled:** normal speed

***First Boot Device/ Second Boot Device/Third Boot Device***

This category determines which drive the system searches first. Take “**Floppy**” for example. System will search in turn for floppy disk drive; then hard disk drive, and finally SCSI drive. Default value is “**Floppy**”. Options are as below:

**Floppy; LS 120; HDD 0; SCSI; CD-ROM; HDD1; HDD2; HDD3; ZIP100; LAN; Disabled.**

---

***Swap Floppy Drive***

**:Enabled:** floppy A&B will be swapped.

**:Disabled(default):** floppy A&B will not be swapped.

***Boot Up Floppy Seek***

BIOS will determine if the floppy disk drive is 40 or 80 tracks. 360k type is 40 tracks while 720K/ 1.2M and 1.44M are all 80 tracks. Default value is "Disabled."

***Boot Up Numlock Status***

**:On(default)**

**:Off**

***Gate A20 option***

**:Normal**

**:Fast(default)**

***Typematic Rate Setting***

This determines the typematic rate.

**Enabled:** enable typematic rate and typematic delay programming.

**Disabled (default):** disable typematic rate and typematic delay programming. The system bios will use default value of this 2 items and the default is controlled by keyboard.

***Typematic Rate(Chars/Sec)***

6 : 6 Characters Per Second(default)

8 : 8 Characters Per Second

10: 10 Characters Per Second

12: 12 Characters Per Second

15: 15 Characters Per Second

20: 20 Characters Per Second

24: 24 Characters Per Second

30: 30 Characters Per Second

---

**Typematic Delay (Msec)**

This is the interval between the first and second character displayed.

**250** : 250 msec (default)

**500** : 500 msec

**750** : 750 msec

**1000** : 1000 msec

**Security Option**

**:Setup** (default)--- security protection in CMOS setup menu

It sets password in BIOS CMOS “**Supervisor Password**” or **User Password,**” the user needs to key in password to enter BIOS CMOS setup.

**:System**---security protection in system boot-up & BIOS setup

This function secures the system under system boot-up and BIOS setup.

***OS Select For DRAM> 64MB***

This option is especially set for OS2 operating system. Set “**OS2**” for RAM memory over 64MB and set “**Non-OS2**” for other operating systems like Windows® 95/98 or Windows NT.

**:Non-OS2** (default)

**:OS2**

---

***Video BIOS Shadow***

It determines whether video BIOS will be copied to RAM. However, it is optional from chipset design. Video shadow will increase the video speed.

**Enabled :** Video Shadow is enabled (default)

**Disabled:** Video Shadow is disabled

***C8000-CBFFF Shadow, CC000-CFFF Shadow, D0000-D3FFF Shadow:  
D4000-D7FFF Shadow, D8000-DBFFF Shadow, DC000-DFFF Shadow***

These are categories determining whether optional ROM will be copied to RAM by 16KB or 32KB per unit and the size depends on chipset.

**:Enabled**

**:Disabled(default)**

---

### 3-4 Chipset Features Setup

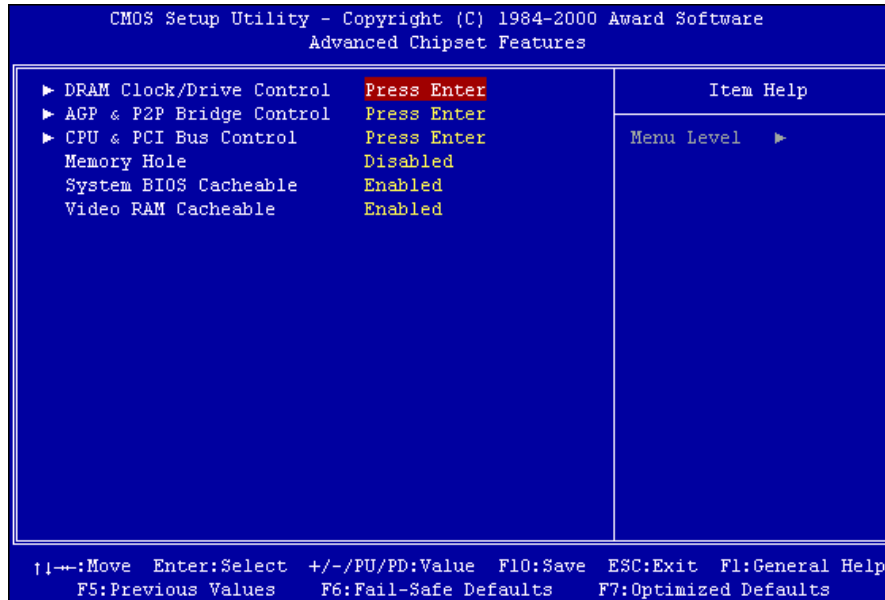



---

***Bank 0/1(2/3) DRAM Timing***

This will determine the timing of SDRAM. The user can separately adjust the timing of bank 0/1, 2/3.

**:SDRAM 10ns**(default)

**:SDRAM 10ns, SDRAM 8ns, Normal, Medium, Fast, Turbo**

**SDRAM Cycle Length:** It controls the DRAM page missing and row miss leadoff timing.

**: 3**(default)

**: 2**

**DRAM Clock:** If your DIMM modules are PC-100 compliant, select this setting.

**:Host CLK**(default)

**:HCLK-33**

**:HCLK+33**

**Memory Hole:**this field enables a memory hole in main memory space. CPU cycles matching an enabled hold are passed on to PCI note that a selection can not be changed while the L2 cache is enabled.

**:Disabled** (default)

**:1.5M - 16M**

**P2C/C2P Concurrency:** The CPU Host is free for other transactions while a PCI transaction takes place.

**:Disabled**

**:Enabled** (default)

**Fast R-W Turn Around:** If a memory read is addressed to a location whose latest write is being held in a buffer before being written to memory, the read is satisfied through the buffer contents, and the read is not sent to the DRAM.

**:Disabled** (default)

**:Enabled**

***System BIOS cacheable***

It defines whether system BIOS area cacheable or not.

**:Enabled** (default)

---

**:Disabled**

***Video RAM cacheable:*** It defines whether video RAM area cacheable or not.

**:Enabled** (default)

**:Disabled**

**Frame Buffer Size**

**:2M**

**:4M**

**:8M**(default)

***AGP Aperture Size***

It selects the size of the Accelerated Graphics Port (AGP) aperture which is a portion of the PCI memory address range dedicated for graphics memory address space. Host cycles that hit the aperture range are forwarded to the AGP without any translation.

**:128MB** (default)

**:128MB, 64MB, 32MB, 16MB, 8MB, 4MB**

**OnCHip USB**

**:Enabled**(default)

Enabling this function adds the function of “**USB Keyboard Support.**”

**:Disabled**

**USB Keyboard Support**

**:Disabled**(default)

**:Enabled**---enable this function when using USB keyboard

**Onchip Sound:**On board AC97 sound function support

**:Enabled**(default)

**:Disabled**

**Onchip Modem:**On board AC97 modem support

**:Disabled**(default)

**:Enabled**

**CPU TO PCI Write Buffer**

---

**:Disabled**  
**:Enabled**(default)  
**PCI Dynamic Bursting**  
**:Disabled**  
**:Enabled**(default)

**PCI Master 0 WS Write**  
**:Disabled**  
**:Enabled**(default)

**PCI Delay Transaction**  
**:Disabled**  
**:Enabled**(default)

**PCI #2 Access #1 Retry**  
**:Disabled**  
**:Enabled**(default)

**AGP Master 1 WS Write**  
**:Disabled** (default)  
**:Enabled**

**AGP Master 1 WS Read**  
**:Disabled** (default)  
**:Enabled**

**Memory Parity/ECC Check**  
**:Disabled** (default)  
**:Enabled**

---

## 3-5 Integrated Peripherals

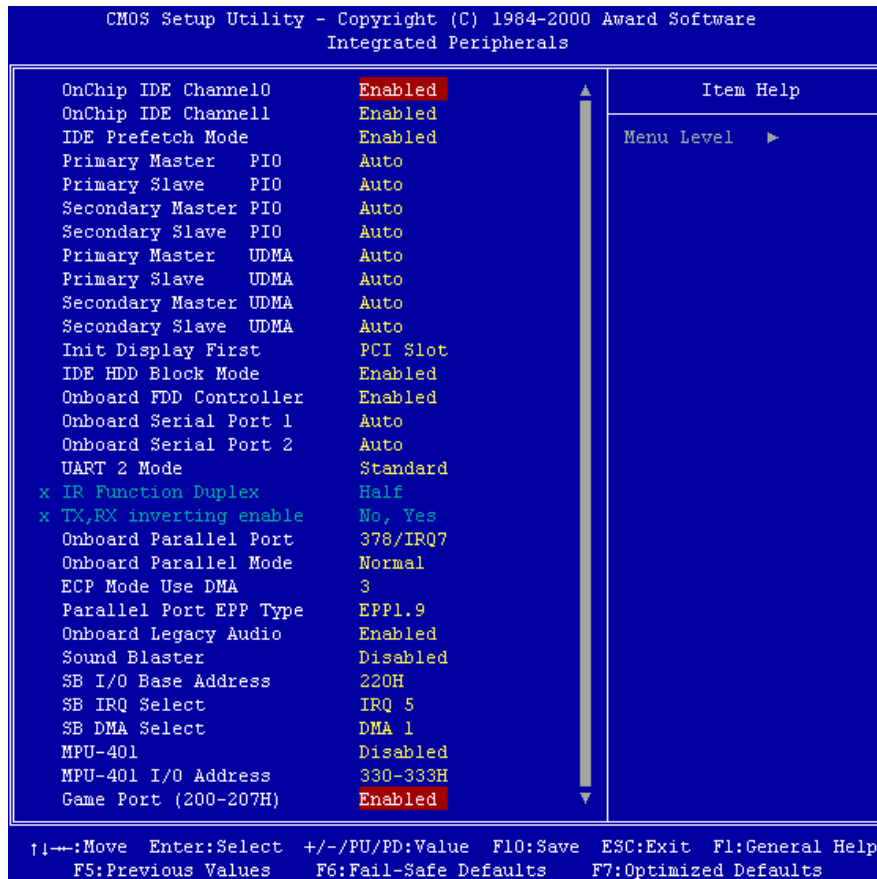

---

***Onchip IDE Channel 0***

**:Disabled**---Disable Primary Master PIO/Primary Slave PIO/Primary Master UDMA/Primary Slave UDMA

**:Enabled---(default)**Enable Primary Master PIO/Primary Slave PIO/Primary Master UDMA/Primary Slave UDMA

***Onchip IDE Channel 1***

**:Disabled**---Disable Secondary Master PIO/Secondary Slave PIO/Secondary Master UDMA/Secondary Slave UDMA

**:Enabled---(default)**Enable Secondary Master PIO/Secondary Slave PIO/Secondary Master UDMA/Secondary Slave UDMA

***IDE Prefetch Mode***

**:Disabled**

**:Enabled (default)**

***Primary Master PIO***

**: Auto (default)**

**: Mode 0**

**: Mode 1**

**: Mode 2**

**: Mode 3**

**: Mode 4**

***Primary Slave PIO***

**: Auto (default)**

**: Mode 0**

**: Mode 1**

**: Mode 2**

**: Mode 3**

**: Mode 4**

---

***Secondary Master PIO***

- : Auto (default)**
- : Mode 0**
- : Mode 1**
- : Mode 2**
- : Mode 3**
- : Mode 4**

***Secondary Slave PIO***

- : Auto (default)**
- : Mode 0**
- : Mode 1**
- : Mode 2**
- : Mode 3**
- : Mode 4**

***Primary Master UltraDMA***

- : Auto (default)**
- : Disable**

***Primary Slave UltraDMA***

- : Auto (default)**
- : Disable**

***Secondary Master UltraDMA***

- : Auto (default)**
- : Disable**

***Secondary Slave UltraDMA***

- : Auto (default)**
- : Disable**

---

***Init Display First***  
: PCI Slot (default)  
:AGP

***IDE HDD Block Mode***  
: Enabled (default)  
: Disabled

***Onboard FDC Controller***  
: Enabled (default)  
: Disabled

***Onboard Serial Port 1***  
: Disabled  
: 3F8/IRQ4  
: 2F8/IRQ3  
: 3E8/IRQ4  
: 2E8/IRQ3  
: Auto (default)

***Onboard Serial Port 2***  
: Disabled  
: 3F8/IRQ4  
: 2F8/IRQ3  
: 3E8/IRQ4  
: 2E8/IRQ3  
: Auto (default)

***UART 2 Mode***  
: Standard (default)  
: HPSIR  
: ASKIR

---

***Onboard Parallel Port***

- : Disabled**
- : 3BC/IRQ7**
- : 378/IRQ7 (default)**
- : 278H/IRQ5**

***Onboard Parallel Port Mode***

<b>Normal (Default)</b>	
<b>EPP</b>	Choosing this item, another line is shown: <b>Parallel Port EPP Type:EPP1.9</b>
<b>ECP</b>	Choosing this item, there is another line shown: <b>ECP Mode Use DMA: 3(default) / 1</b>
<b>ECP/EPP</b>	Choosing this item, another line is shown: <b>ECP Mode Use DMA: 3(default) / 1</b> <b>Parallel Port EPP Type:EPP1.9</b>

***ECP Mode Use DMA***

- : 1**
- : 3 (default)**

***Parallel Port EPP TYPE***

- :EPP1.9(default)**
- :EPP1.7**

***Onboard Legau Audio***

- :Enabled (default)**
- :Disabled**

***Sound Blaster***

- :Enabled**
- :Disabled (default)**



---

***SB I/O Base Address***

**:220H**(default)  
**:240H**  
**:260H**  
**:280H**

***SB IRQ Select***

**:IRQ5**(default)  
**:IRQ7**  
**:IRQ9**  
**:IRQ10**

***SB DMA Select***

**:DMA1** (default)  
**:DMA0**  
**:DMA2**  
**:DMA3**

***MPU-401***

**:Enabled**  
**:Disabled**(default)

***MPU-401 I/O Address***

**: 300-303H**  
**:310-313H**  
**:320-323H**  
**:330-333H** (default)

***Game Port (200-207H)***

**:Enabled** (default)  
**:Disabled**

---

## 3-6 Power Management Setup

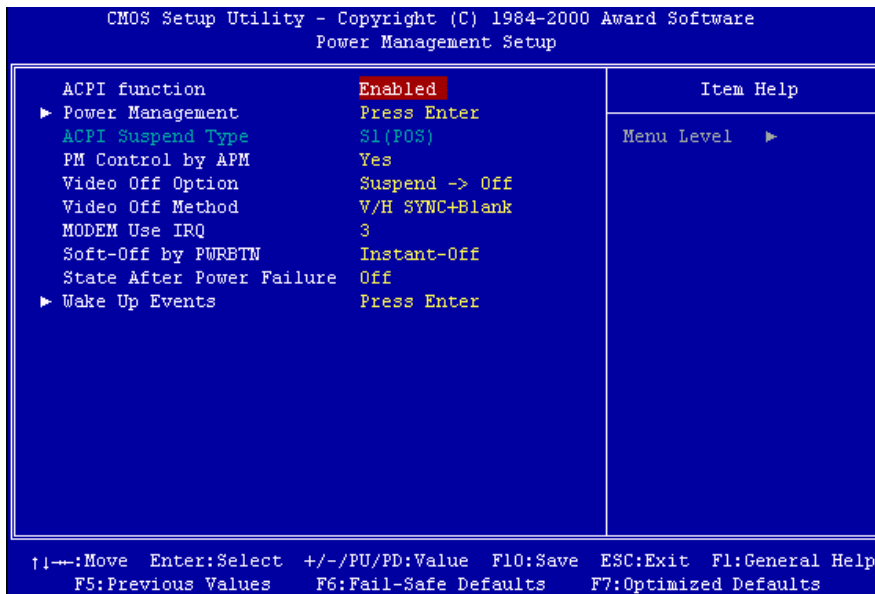

---

***ACPI Function***

**:Disabled**

**:Enabled (default)**

***Power Management***

Choosing “User Define,” users can configure their own power management

Item	Doze Mode	Standby Mode	Suspend Mode
User Define	Disable	Disable	Disable
Max Saving	10 Sec	10 Sec	10 Sec
Min Saving	1 Hour	1 Hour	1 Hour

***ACPI Suspend Type***

**:S1 (POS) (default)**

***PM Control by APM***

**:Yes (default)**

**:No**

***Video Off Option***

**: Suspend-off (default)**

**: Always on**

**: All modes-off**

***Video Off Method***

**: V/H Sync+Blank (default)**

**: DPMS Supported**

**: Blank Screen**

***MODEM Use IRQ***

**: 3 (default)**

**: 4, 5, 7, 9,10,11,NA**

---

***Soft-off by PWRBTN***

**:Delay 4 sec**

**:Instant-off(default)**

***Stat After Power Failure***

**:Off (default)**

**:**

***Wake Up Events***

ITEM	Default	
VGA	OFF	ON
LPT & COM	LPT/COM	None; LPT; COM
HDD & FDD	ON	OFF
PCI Master	OFF	ON
Modem Ring Resume	Disabled	Enabled
RTC Alarm Resume	Disabled	Enabled
Date (of Month)	1 - 31	
Resume time	xx:xx:xx	
Primary INTR	ON	OFF



*Note: this function only works when the system is turned off from Windows mode, and Doze mode will not function.*

---

### 3-7 PNP / PCI Configuration Setup

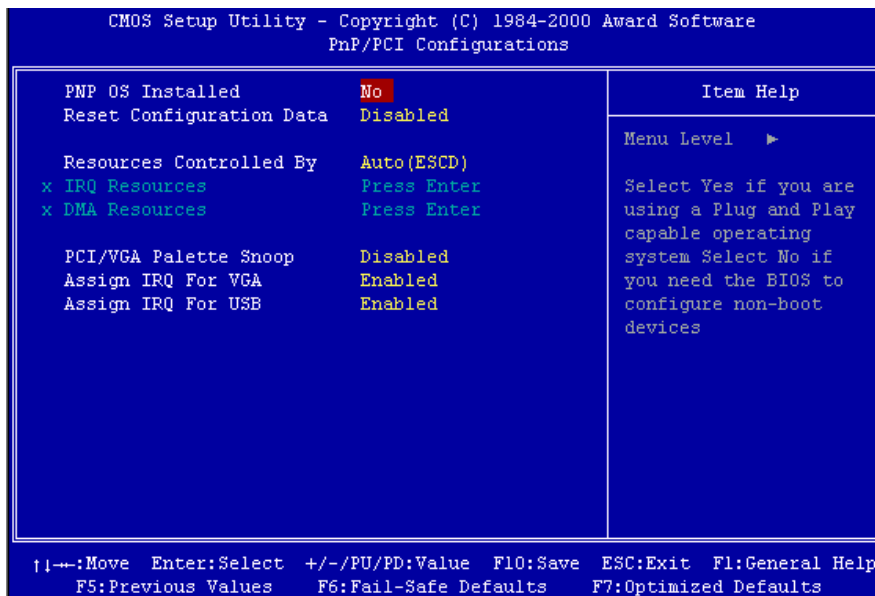

---

***PnP OS Installed***

:**No**(default) -- OS will not recognize PnP devices

:**Yes** -- OS will arrange the setup of PnP devices

***Reset Configuration Data***

: **Disabled**(default)

: **Enabled**--- to reset “**Extended System Configuration Data(ESCD)** when you exit setup if you have installed a new add-on card and the system reconfiguration has caused such a serious conflict that the operating system can not boot up.

***Resources Controlled By***

: **Manual**

The table will show the below items: “**Reset Configuration Data, IRQ-3 assigned to, DMA-0 assigned to.**” The user can adjust the shown items as required.

: **Auto** (default)

The table will not show the above items, and the system will automatically assign the above setup.

**PCI/VGA Palette Snoop**

: **Enabled**

: **Disabled**(default)

**Assigned IRQ for VGA**

: **Enabled** (default)

: **Disabled**

**Assigned IRQ for USB**

: **Enabled** (default)

: **Disabled**

---

### 3-8 PC Health Status

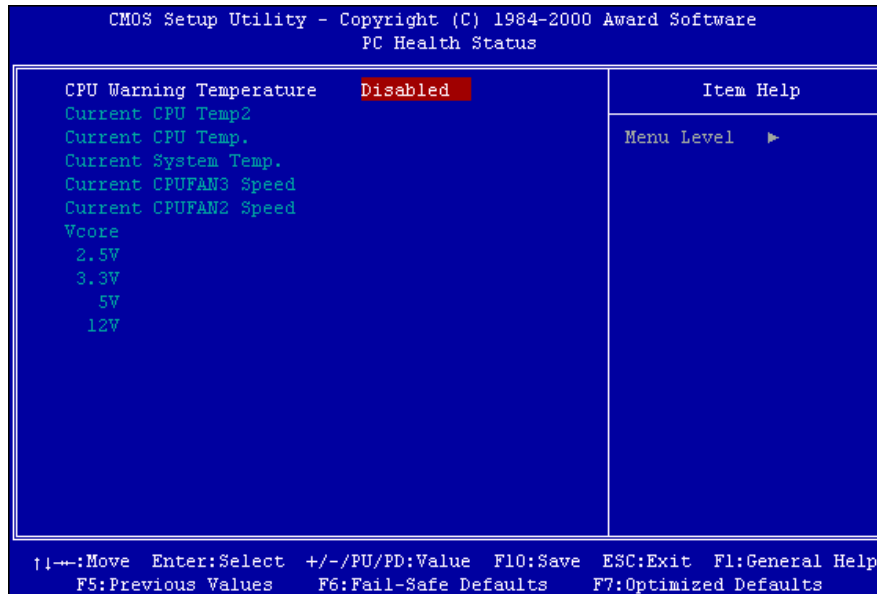

---

***CPU Warning Temperature***

**: Enabled**

**: Disabled(default)**

***Current CPU Temp.***

This item reflects the CPU temperature as measured by RT1, the thermistor located under the CPU. Temperatures over 60 degrees are too high and a better cooling solution must be found for the CPU

***Current system Temp.***

This item reflects the system temperature as measured by RT2, the thermistor located close to the BIOS IC. Temperatures over 45 degrees are too high and a better cooling solution must be found for the computer case (like adding a case FAN)

***Current CPU FAN 1 Speed***

The speed of the CPU FAN connected to FAN 1 is displayed here. If you have problems with this item, please refer to the FAQ chapter boot section.

***Current CPU FAN 2 Speed***

The speed of the CPU FAN connected to FAN 2 is displayed here

***Voltage X***

The Voltage for the voltage line (Vcore, 3.3V, 5V, 12V) are displayed here. A small deviation of the ideal value is not a problem because voltages always fluctuate.



---

### 3-9 Frequency/Voltage Control

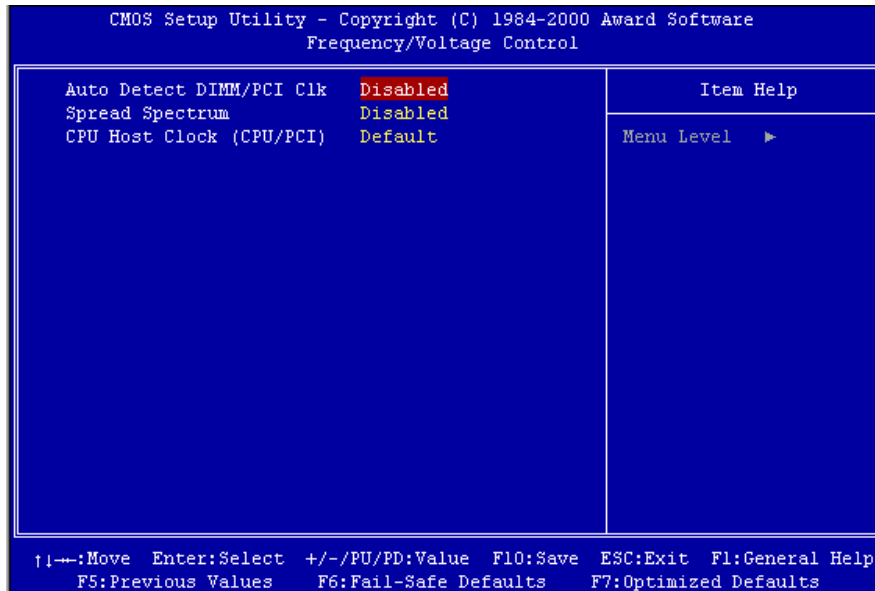

***Auto Detect DIMM/PCI Clk***

: Enabled  
: Disabled(default)

***Spread Spectrum***

: Enabled  
: Disabled(default)

***CPU Host Clock (CPU/PCI)***

: 90/30 – 166/41  
: Default

---

## 3-10 Password Setting

The "Supervisor/User Password setting" utility sets the security protection. There are two kinds of password functions in the setup menu : one is "Supervisor Password," and the other is "User Password." Their difference is:

Supervisor Password: this function allows you the right to change the options of setup menu.

User Password: this function only allows you to enter the setup menu but not to change the options of the setup menu except "USER PASSWORD," "SAVE & EXIT SETUP," and "EXIT WITHOUT SAVING."

### 1. How to set "Supervisor Password" & "User Password"

#### Step 1: Enter Password

Press <Enter> after appointing the password.

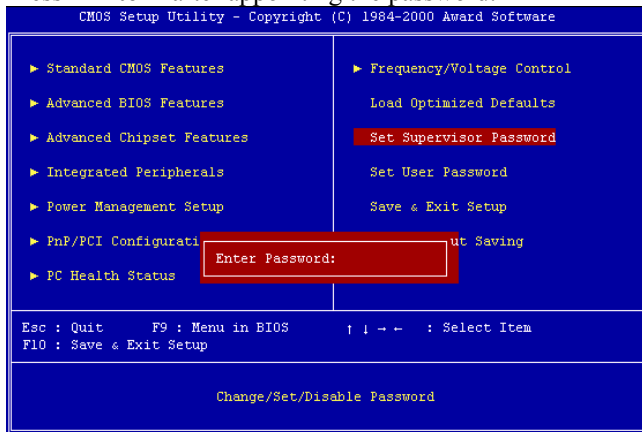

---

## Step 2: Confirm Password

Type the password again and press <Enter> .

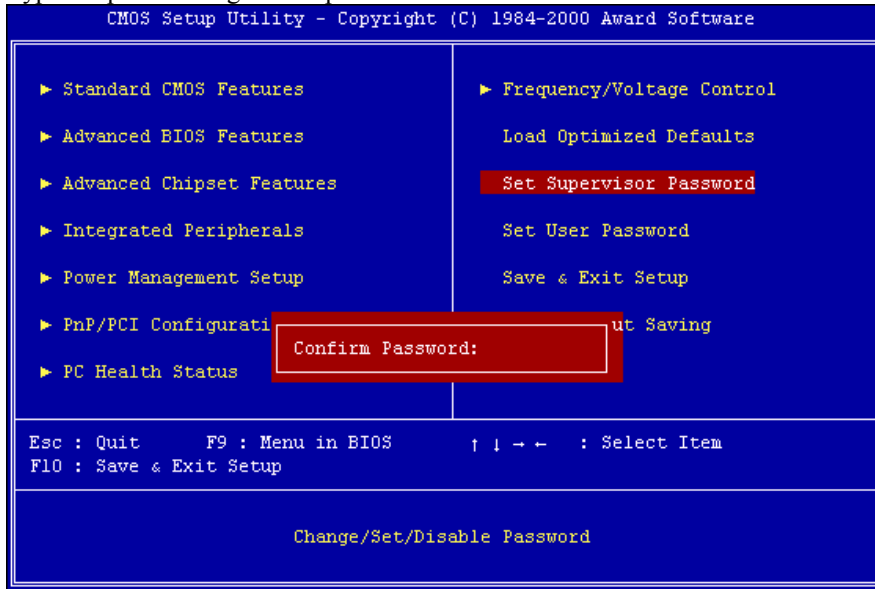

**Note:** If you forget password, please clear CMOS.  
(refer to JBAT1 CMOS status )

## Step 3: Set “Security Option” in “BIOS Features Setup”

After setting password, enter “Security Option” in “BIOS Features Setup.” There are 2 options “Setup” & “System.” “Setup” secures CMOS setup. “System” secures PC system and password is required during system boot-up and CMOS setup..

---

## 2. How to disable Password Setting

Step 1: **Go to CMOS Setup Menu** (need to key in password first)

### Step 2: Enter Password Setting

When it shows “Enter Password.” Press the <Enter> key instead of entering a new password when “ENTER PASSWORD” appears. It will inform “PASSWORD DISABLED PRESS ANY KEY TO CONTINUE.” Press any key as instructed to disable password.

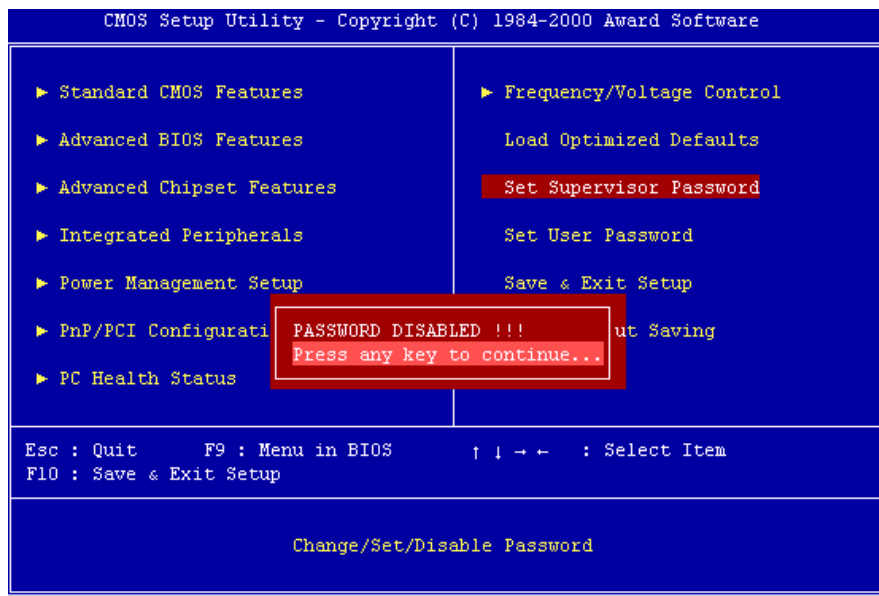

---

The Award® BIOS supports 3 HDD modes: **NORMAL, LBA & LARGE.**

**1. Normal mode**

Generic access mode in which neither the BIOS nor the IDE controller will make any transformations during accessing.

The maximum number of cylinders, head & sectors for normal mode are **1024, 16 & 63.**

No. Cylinder	(1024)
X No. Head	(16)
X No. Sector	(63)
<u>X No. Per Sector</u>	<u>(512)</u>
	528 MB

If user set this HDD to normal mode, the maximum accessible HDD size will be 528 MB even though its physical size may be greater than that!

**2. LBA (Logical Block Addressing) Mode**

A new HDD accessing method to overcome the 528 MB bottleneck. The number of cylinders, heads & sectors shown in setup may not be the number physically contained in the HDD. During HDD accessing, the IDE controller will transform the logical address described by sector, head & cylinder into its own physical address inside the HDD.

The maximum HDD size supported by LBA mode is 8.4 GB which is obtained by the following formula:

No. Cylinder	(1024)
X No. Head	(255)
X No. Sector	(63)
<u>X No. Bytes Per Sector</u>	<u>(512)</u>
	8.4 GB

---

### 3. Large Mode

Extended HDD access mode supported by Award® software. Some IDE HDDs contain more than 1024 cylinder without LBA support (in some cases, user do not want LBA). The Award® BIOS provides another alternative to support these kinds of large mode:

<u>Cyls.</u>	<u>Head</u>	<u>Sector</u>	<u>Mode</u>
1120	16	59	NORMAL
560	32	59	LARGE

BIOS tricks DOS (or other OS) that the number of cylinders is less than 1024 by dividing it by 2. At the same time, the number of heads is multiplied by 2. A reverse transformation process will be made inside int 12h in order to access the right HDD address the right HDD address!

### 4. Maximum HDD Size:

	No. Cylinder	(1024)
X	No. Head	(32)
X	No. Sector	(63)
X	<u>No. Bytes Per Sector</u>	<u>(512)</u>

1 GB



**To support LBA or large mode of HDDs**, there must be some softwares involved. All these softwares are located in the Award® HDD service routine (int 13h). It may be failed to access a HDD with LBA (large) mode selected if you are running under an operating system which replaces the whole int 13h. Unix operating systems do not support either LBA or large and must utility the standard mode. Unix can support drives larger than 528MB.

---

### 3-11 Load Optimized Defaults

"Load Optimized Defaults" loads optimized settings which are stored in the BIOS ROM. The auto-configured settings only affect "BIOS Features Setup" and "Chipset Features Setup" screens. There is no effect on the standard CMOS setup. To use this feature, highlight it on the main screen and press the <Enter> key. A line will appear on screen asking if you want to load the setup default values. Press the <Y> key and then press the <Enter> key. The setup defaults will then load. Press <N> if you don't want to

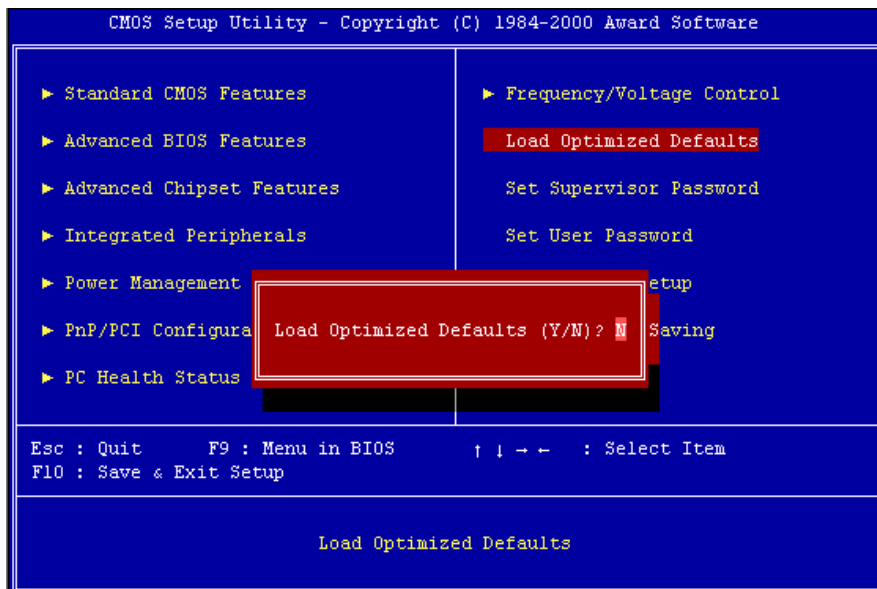

---

## 3-12 Save & Exit Setup

The "Save & Exit Setup" option will bring you back to boot up procedure with all the changes, you have made which are recorded in the CMOS RAM.

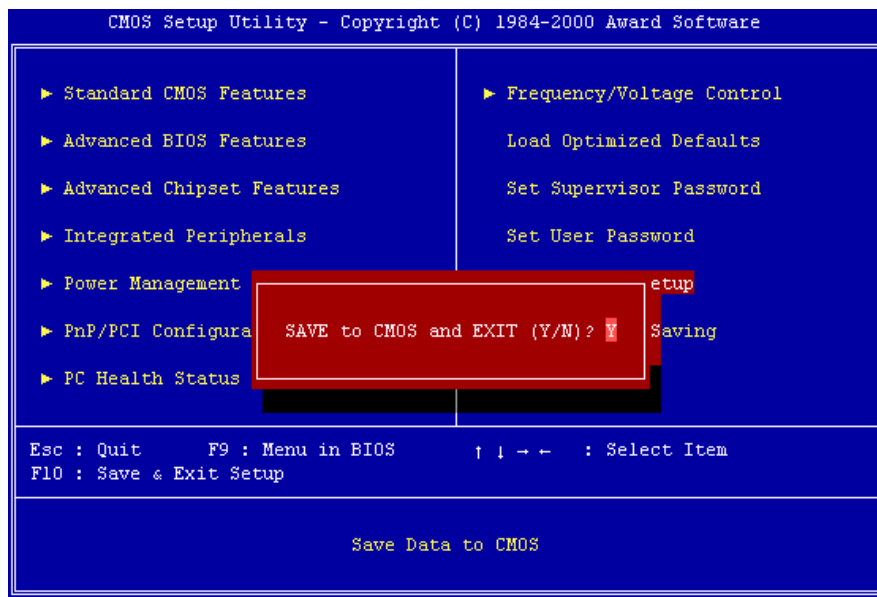



---

### 3-13 Quit Without Saving

The "Quit Without Saving" option will bring you back to normal boot up procedure without saving any data into CMOS RAM. All of the old data in the CMOS will not be destroyed.

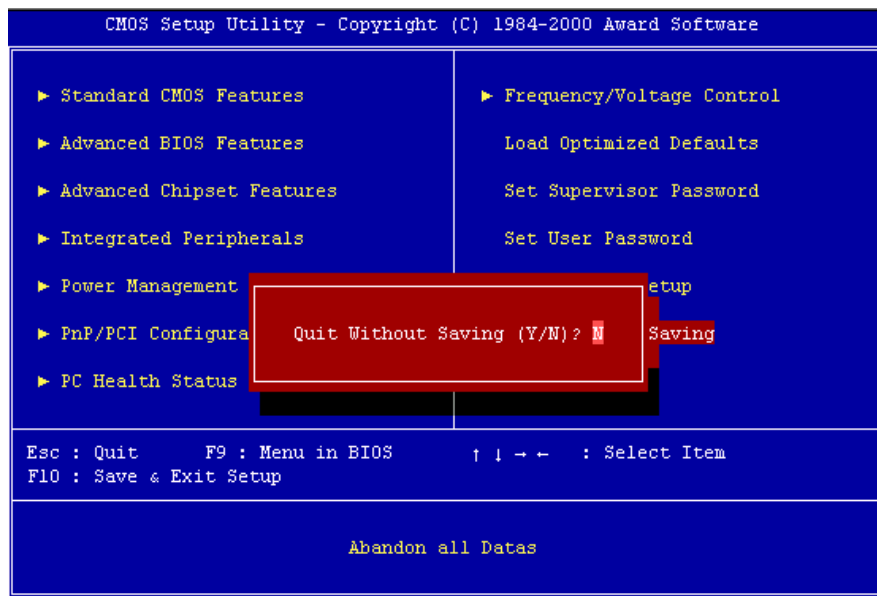

---

## Chapter 4 Appendix

### 4-1 Memory Map

Address range	Size	Description
00000-7FFFF	512K	Conventional memory
80000-9FBFF	127K	Extended conventional memory
9FC00-9FFFF	1K	Extended BIOS data area if PS/2 mouse is installed
A0000-C7FFF	160K	Available for hi DOS memory
C8000-DFFFF	96K	Available for hi DOS memory and adapter ROMs
E0000-EEFFF	60K	Available for UMB
EF000-EFFFF	4K	Video service routine for monochrome & CGA adapter
F0000-F7FFF	32K	BIOS CMOS setup utility
F8000-FCFFF	20K	BIOS runtime service routine (2)
FD000-FDFFF	4K	Plug and play ESCD data area
FE000-FFFFF	8K	BIOS runtime service routine (1)

---

## 4-2 I/O Map

000-01F	DMA controller (master)
020-021	Interrupt controller (master)
022-023	Chipset control registers. I/O ports
040-05F	Timer control registers
060-06F	Keyboard interface controller (8042)
070-07F	RTC ports & CMOS I/O ports
080-09F	DMA register
0A0-0BF	Interrupt controller (slave)
0C0-0DF	DMA controller (slave)
0F0-0FF	Math coprocessor
1F0-1FB	Hard disk controller
278-27F	Parallel port 2
2B0-2DF	Graphics adapter controller
2F8-2FF	Serial port 2
360-36F	Network ports
378-37F	Parallel port 1
3B0-3BF	Monochrome & parallel port adapter
3C0-3CF	EGA adapter
3D0-CDF	CGA adapter
3F0-3F7	Floppy disk controller
3F8-3FF	Serial port-1

---

## 4-3 Time & DMA Channels Map

### Time map:

Timer channel 0 system timer interrupt  
Timer channel 1 DRAM refresh request  
Timer channel 2 speaker tone generator

### DMA channels:

DMA channel 0 available  
DMA channel 1 onboard ECP (option)  
DMA channel 2 floppy disk (SMC chip)  
DMA channel 3 onboard ECP (default)  
DMA channel 4 cascade for DMA controller 1  
DMA channel 5 available  
DMA channel 6 available  
DMA channel 7 available

---

## 4-4 Interrupt Map

**NMI:** non-maskable interrupt

**IRQ(H/W):**

- 0 system timer interrupt from timer 0
- 1 keyboard output buffer full
- 2 cascade for IRQ 8-15
- 3 serial port2
- 4 serial port1
- 5 parallel port 2
- 6 floppy disk (SMC chip)
- 7 parallel port 1
- 8 RTC clock
- 9 available
- 10 available
- 11 available
- 12 PS/2 mouse
- 13 math coprocessor
- 14 onboard hard disk (IDE1) channel
- 15 onboard hard disk (IDE2) channel

---

## 4-5 RTC & CMOS RAM Map

### RTC & CMOS :

00	seconds
01	seconds alarm
02	minutes
03	minutes alarm
04	hours
05	hours alarm
06	day of week
07	day of month
08	month
09	year
0a	status register a
0b	status register b
0c	status register c
0d	status register d
0e	diagnostic status byte
0f	shutdown byte
10	floppy disk drive type byte
12	hard disk type byte
13	reserve
14	equipment type
15	base memory low byte
16	base memory high byte
17	extension memory low byte
18	extension memory high byte
19-2d	
2e-2f	
30	Reserved for extension memory low byte
31	reserved for extension memory high byte
32	date century byte
33	information flag
34-3f	reserve
40-7f	reserved for chipset setting data

---

## 4-6 ISA I/O Address Map

I/O Address (HEX)	I/O device
000 - 01F	DMA Controller 1, 8237A-5
020 - 03F	Interrupt Controller 1, 8259A
040 - 05F	System Timer, 8254-2
060 - 06F	8042 Keyboard Controller
070 - 07F	real-time Clock/CMOS and NMI Mask
080 - 09F	DMA Page Register, 74LS612
0A0 - 0BF	Interrupt Controller 2, 8259A
0C0 - 0DF	DMA Controller 2, 8237A-5
0F0 - 0FF	i486 Math Coprocessor
1F0 - 1F8	Fixed Disk Drive Adapter
200 - 207	Game I/O
20C - 20D	Reserved
21F	Reserved
278 - 27F	Parallel Printer Port 2
2B0 - 2DF	Alternate Enhanced Graphic Adapter
2E1	GPIB Adapter 0
2E2 - 2E3	Data Acquisition Adapter 0
2F8 - 2FF	Serial Port 2 (RS-232-C)
300 - 31F	Prototype Card
360 - 363	PC Network (Low Address)
364 - 367	Reserved
368 - 36B	PC Network (High Address)
36C - 36F	Reserved
378 - 37F	Parallel Printer Port 1
380 - 38F	SDLC, Bisynchronous 2
3B0 - 3BF	Monochrome Display and Printer Adapter

---

<b>I/O Address (HEX)</b>	<b>I/O device</b>
390 - 393	Cluster
3A0 - 3AF	Bisynchronous 1
3C0 - 3CF	Enhanced Graphics Adapter
3D0 - 3DF	Color/Graphics Monitor Adapter
3F0 - 3F7	Diskette Drive Controller
3F8 - 3FF	Serial Port 1 (RS-232-C)
6E2 - 6E3	Data Acquisition Adapter 1
790 - 793	Cluster Adapter 1
AE2 - AE3	Data Acquisition Adapter 2
B90 - B93	Cluster Adapter 2
EE2 - EE3	Data Acquisition Adapter 3
1390 - 1393	Cluster Adapter 3
22E1	GPIB Adapter 1
2390 - 2393	Cluster Adapter 4
42E1	GPIB Adapter 2
62E1	GPIB Adapter 3
82E1	GPIB Adapter 4
A2E1	GPIB Adapter 5
C2E1	GPIB Adapter 6
E2E1	GPIB Adapter 7



---

## Chapter 5 Q & A

### 5-1 Errors Messages During Power On Self Test

During **power on self test (post)**, BIOS will automatically detect the system devices. Below is the question that users most often meet. The user may press “**Esc**” key to skip the full memory test.

#### **1. Beep sound**

On power on, the system make beep sound to offer different messages. If the system is configured correctly, it prompts a short beep to show device configuration is done correctly. When VGA card and DIMM modules are not plugged well, the system makes longer and constant beep sounds.

#### **2. BIOS ROM checksum error**

It indicates the checksum of the BIOS code is not right and system will always halt on power on screen. Contact the dealer to exchange a new BIOS.

#### **3. CMOS battery fails**

It indicates the CMOS battery does not work. Contact the dealer to exchange a new battery.

#### **4. CMOS checksum error**

It indicates the CMOS checksum is incorrect. Load the default values in BIOS to solve this problem. This error may result from a weak BIOS, so exchange a new BIOS if necessary.

#### **5. Hard disk initialize**

**Please wait a moment...**

Some hard drives require more time to initialize.

---

**6. *Hard disk install failure***

The system can not find or initialize the hard drive controller or the drive. Check if the controller is set correctly. If no hard disk is installed, “**Hard drive selection**” must be set to “**none.**”

**7. *Keyboard error or no keyboard present***

This means the system can not initialize the keyboard. Check if the keyboard is plugged well and be sure no keys are pressed during power on self test.

**8. *Memory test fails***

There will be more information to specify the type and location of the memory error.

**9. *Primary master hard disk fail***

The BIOS find an error in the primary master hard disk drive.

**10. *Primary slave hard disk fail***

The BIOS finds an error in the primary slave hard disk drive.

**11. *Secondary master hard disk fail***

The BIOS finds an error in the secondary slave master hard disk drive.

**12. *Secondary slave hard disk fail***

The BIOS finds an error in the secondary slave IDE hard disk drive.

