



User Guide
TC440 NLX Motherboard

www.trimond.com

Document History

<i>Issue</i>	<i>Description</i>	<i>Date</i>
1.0	Preliminary	May 98
1.1	Update for production motherboards	August98
1.2	Supplemental Connector information added	August 98
1.3	Style update, added installation and upgrade guides	October 98
1.4	Information amended	February 99
1.5	Information amended	May 99

Trademarks mentioned within this document are the properties of their respective owners. Details available on request.

Information contained in this document is subject to change without notice and does not represent a commitment on the part of Mitsubishi Electric Motherboard Division.

No part of this manual may be reproduced or transmitted in any form or by any means electronic or mechanical including photocopying and recording, for any purpose, without the express written permission of the publishers.

Published by:
Mitsubishi Electric
Motherboard Division
3500 Parkside
Birmingham Business Park
Birmingham, England
B37 7YS

SAFETY AND REGULATORY NOTICES

GENERAL

Battery

This product contains a lithium battery.

Do not use a metal or other conductive implement to remove the battery. If a short-circuit is made between its positive and negative terminals the battery may explode.

Replace a discharged battery with one of the same type; another type may explode or ignite. Follow the instructions contained in section 3 of this document to replace the battery. Dispose of a discharged battery promptly and in accordance with the battery manufacturer's recommended instructions. Do not recharge, disassemble or incinerate the discharged battery. Keep discharged batteries away from children.

Anti-static precautions

Warning

Static electricity can cause permanent damage to electronic components. You should be aware of this risk, and take precautions against the discharge of static electricity.

This product is at risk from static discharge because the electronic components of the motherboard are exposed. Memory modules and replacement processors are examples of electrostatic sensitive devices (ESSDs).

All work that involves contact with the TC440 NLX Motherboard should be done in an area completely free of static electricity. We recommend using a Special Handling Area (SHA) as defined by EN 100015-1: 1992. This means that working surfaces, floor coverings and chairs must be connected to a common earth reference point, and you should wear an earthed wrist strap and anti-static clothing. It is also a good idea to use an ionizer or humidifier to remove static from the air.

Handle static-sensitive items with extreme care. Hold add-on components only by their edges, avoiding their electrical contacts. In general, do not handle static-sensitive items unnecessarily.

Keep all conductive material, and food and drink, away from your work area and the TC440 NLX Motherboard.

LEGALITIES

This product complies with the relevant clauses of the following European Directives (and all subsequent amendments):

Low Voltage Directive **73/23/EEC**

EMC Directive **89/336/EEC**

CE Marking Directive **93/68/EEC**

Important

This product, when supplied, complies with the CE Marking Directive and its strict legal requirements. Use only parts tested and approved by Mitsubishi Electric Motherboard Division.

STANDARDS

Safety

This product complies with the American Safety Standard **UL1950**.

Electro-magnetic Compatibility (EMC)

This product complies with the following European EMC standards:

Emissions **EN55022 Class B**

Immunity **EN55024**

This product also complies with the following American EMC standard:

FCC Class B

FCC Compliance Statement

Note: This equipment has been tested and found to comply with the limits for a Class B digital device, pursuant to part 15 of the FCC Rules. These limits are designed to provide reasonable protection against harmful interference in a residential installation. This equipment generates, uses and can radiate radio frequency energy and, if not installed and used in accordance with the instructions, may cause harmful interference to radio communications. However, there is no guarantee that interference will not occur in a particular installation. If this equipment does cause harmful interference **to** radio or television reception, which can be determined by turning the equipment off and on, the user is encouraged to try to correct the interference by one or more of the following measures:

- ◆ Reorient or relocate the receiving antenna.
- ◆ Increase the separation between the equipment and receiver.
- ◆ Connect the equipment into an outlet on a circuit different from that to which the receiver is connected.
- ◆ Consult the dealer or an experienced radio/TV technician for help.

<i>Important</i>

You are cautioned that any change or modification to the product not expressly approved by the manufacturer could void the approvals held by this product.

CONTENTS

1	Overview	8
	Motherboard Features.....	9
	Configuration Options.....	10
	Build-time.....	10
	User Configurable.....	10
	Block Diagram.....	11
2	Installation guide	12
	Connector Location Diagram.....	12
	Jumper Descriptions.....	13
3	Upgrading the motherboard	15
	Adding more memory.....	15
	Fitting and removing DIMMs.....	15
	Fitting a DIMM.....	16
	Removing a DIMM.....	16
	Adding more video memory.....	16
	The processor assembly.....	17
	To fit a new processor.....	18
	Replacing the battery for the configuration CMOS.....	19
4	Electronics	20
	Processor.....	20
	Core Logic.....	20
	Concurrency.....	21
	Level 2 Cache.....	21
	Memory.....	21
	DIMM.....	21
	BIOS.....	21
	Video.....	22
	VGA Controller.....	22
	AGP.....	23
	Audio.....	24
	ESS Solo 1.....	24
	Real Time Clock.....	24

Standard I/O	25
Keyboard and Mouse	25
Floppy Disk Interface	25
Serial Ports.....	25
Parallel Port	25
Additional I/O.....	25
IDE Disk Controller.....	25
Universal Serial Bus (USB).....	25
Security.....	25
Motherboard Power	26
Processor Power.....	26
Battery.....	26
Power Management	26
Standby Switch	26
Behaviour After AC-Disconnect.....	26
Sleep State Indication	26
System Management	27
Heceta II System Monitor	27
Fan Control.....	27
Expansion Slots	27
Industry Standard Architecture (ISA)	27
Peripheral Component Interconnect (PCI).....	27
Bus Resource Utilisation	28
ISA DMA Channels.....	28
ISA Interrupts	28
PCI Interrupts.....	29
PCI Device Selection (motherboard devices).....	29
PCI Arbitration	29
5 BIOS Setup & POST	30
BIOS Setup.....	30
Control keys.....	30
Getting help in BIOS Setup	31
Reserving ISA legacy resources	31
Multi-boot facility	31
Power-on self-test.....	32
Recoverable POST errors	32

Terminal POST errors and beep codes	33
6 Electrical	40
Power Requirements.....	40
PCB	40
7 Connector Assignments	41
Keyboard and Mouse (PS/2 Mini-DIN).....	41
Serial Port 1 and Serial Port 2 (9 way D-type).....	41
Parallel Port (25 way D-type)	42
VGA (15 way high density D-type).....	43
USB Ports 0 and 1 (USB port 1 on the rear panel is an option).....	43
Line Input and Output (3.5mm stereo jack).....	43
Microphone Input (3.5mm stereo jack).....	44
Processor Fan (3 way header with locking ramp).....	44
Internal CD audio (4 way ATAPI header)	44
MIDI/Joystick (16 way dual row header)	44
VESA/AMCC Support (40 way dual row header).....	45
AGP Connector.....	46
NLX Connector (gold fingers).....	48

1 OVERVIEW

TC440 NLX is a dual Pentium® II or Pentium® III processor-based NLX profile motherboard.

The design of TC440 NLX is based around the following components.

- ◆ Intel Pentium® II or Pentium® III processors in Slot 1 package.
- ◆ Intel 440BX host bridge and system controller.
- ◆ Intel PIIX4e ISA bridge and peripheral and power management controller.
- ◆ National Semiconductor 87351 I/O Combo.
- ◆ ATI AGP 3D Rage Pro AGP or 3D Rage IIC AGP video controller with SGRAM frame buffer.
- ◆ ESS Solo 1 PCI audio controller.

Processor

The Pentium® II and Pentium® III processors are based on the P6 micro-architecture and include MMX technology. Two package versions for the Slot 1 connectors are available - SECC (Pentium® II) and SECC2 (Pentium® II and Pentium® III).

440BX North bridge

The 440BX North bridge connects the processor to the SDRAM main memory, an AGP port and PCI bus interface. The device is housed in a 492-pin BGA package.

PIIX4e ISA bridge

The PIIX4e provides the PCI to ISA bus bridge and contains the system's RTC, the IDE interfaces, the DMA and Interrupt Controllers. The PIIX4e also provides ACPI support, an SMBus controller and all the general purpose I/O ports used on the TC440 NLX motherboard. The PIIX4e device is packaged in a 324 pin BGA.

MOTHERBOARD FEATURES

Form factor	NLX, 9.0" wide x 13.6" long
Processor	Dual Slot 1 with VRM8.2 regulators on the motherboard. Accepts all Pentium® II and Pentium® III 100MHz bus processors
Core logic	Intel 440BX & PIIX4e
Cache	L2 cache included on processor module.
Memory – RAM	3 DIMM sockets to accept 168 pin un-buffered PC100 SDRAM modules. 64-bit or 72-bit ECC with 1-bit correct, 2-bit detect.
Memory - Flash ROM	2Mb flash ROM. Includes BIOS, Setup-in-ROM, VGA, USB, DMI, 120MB floppy etc.
Buses	Supports 4 bus-master PCI slots and 5 ISA slots via riser.
VGA	AGP video via ATI Rage IIC or ATI Rage Pro. 2 or 4MB SGRAM with upgrades via SODIMM module AGP connector
Audio – controller	Active speaker support only (external). Internal mono speaker and PCB mounted ‘beeper’. ESS Solo 1 CODEC.
Hard Disk & CD-ROM	Dual UltraDMA33 interfaces for hard disk and CD-ROM.
Floppy Disk	720kB, 1.2MB (3-mode), 1.44MB 3½ drives, 1.2MB 5¼ drives. Support for 120MB drives via ATA port.
Parallel Port	IEEE 1284 (ECP & standard) on 25-way D-type
Serial Ports	Dual 16550s. Two 9-way D-types on rear edge of motherboard.
USB	Two ports. Two configurations available as build option. Either two ports on rear panel or one on rear and second through NLX riser.
Keyboard & Mouse	PS/2-style connectors.
Security	Chassis intrusion detection via riser.
Power Management	Green and deep green via system management mode. ACPI compatible. Requires logic-controlled PSU. Standby option with wake-up on interrupt, serial port activity or button.
System Management	Hardware monitoring (Voltage, temperature and fan monitor) via optional Heceta II device.
Plug & Play	PC97 and PC98 compliant
Battery back-up	On-board lithium coin cell with 5 years typical life.
PCB	4-layer NLX form-factor. All components on top side

CONFIGURATION OPTIONS

Build-time

The following items can be configured at build-time and cannot be modified by the user.

- ◆ Video controller (Rage IIC or Rage Pro).
- ◆ Video memory and upgrade socket.
- ◆ AMC connector.
- ◆ MIDI & joystick header.
- ◆ Heceta II system monitor.
- ◆ +5V supply to VGA connector pin 9.
- ◆ Dual rear USB or single rear and riser.

Please contact Mitsubishi Electric Motherboard Division to determine available configurations.

User Configurable

The user can configure the following items.

- ◆ Processor (Intel boxed products)
- ◆ Main memory DIMMs
- ◆ Video memory upgrade (where available)
- ◆ Processor speed (core/bus ratio)
- ◆ BIOS ROM write enable
- ◆ Fan monitor selection
- ◆ Function enable/disable via jumpers (audio CODEC, VGA)

BLOCK DIAGRAM

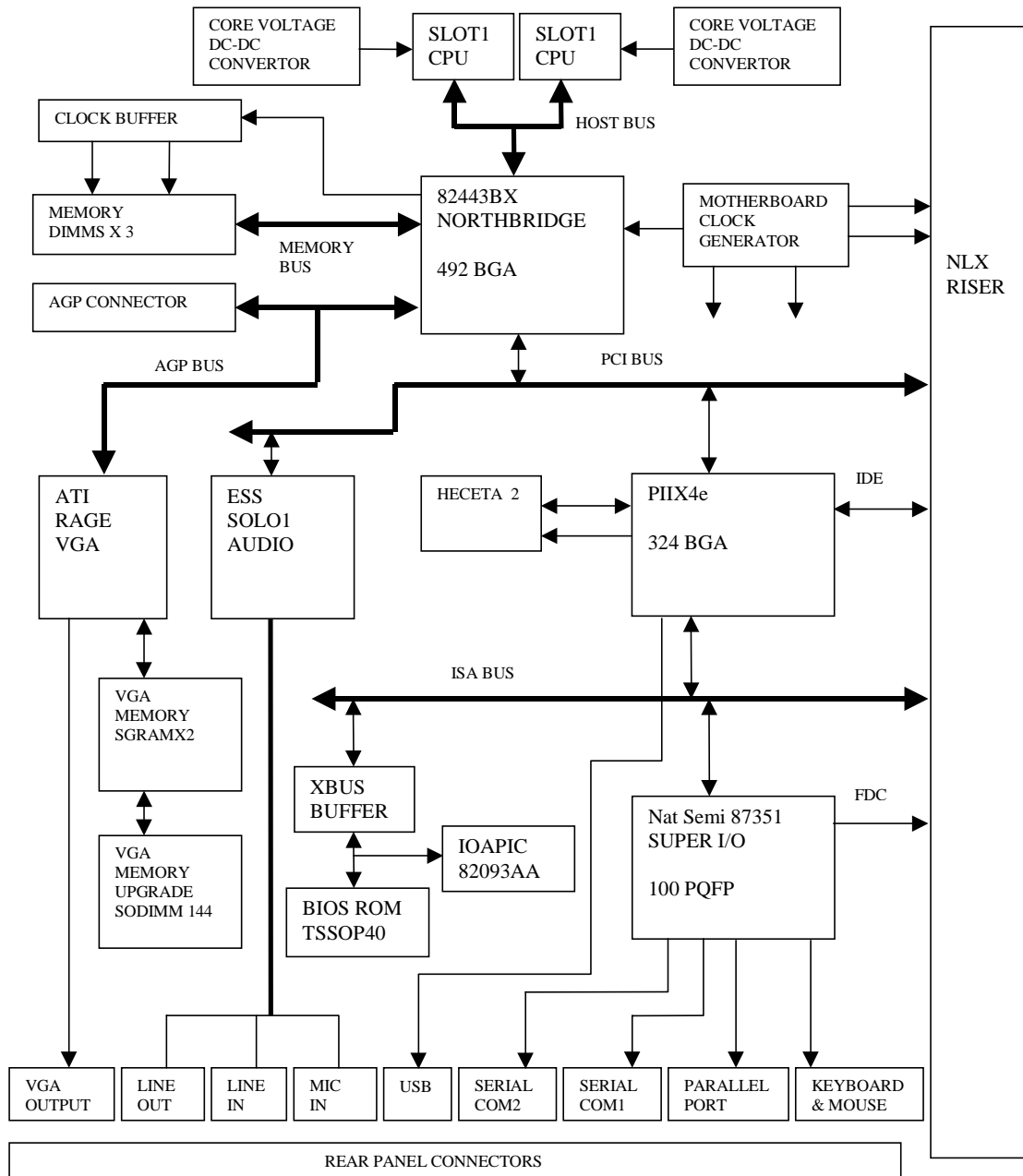

2 INSTALLATION GUIDE

Warning

Static electricity can cause permanent damage to electronic components. You should be aware of this risk, and take precautions against the discharge of static electricity.

CONNECTOR LOCATION DIAGRAM

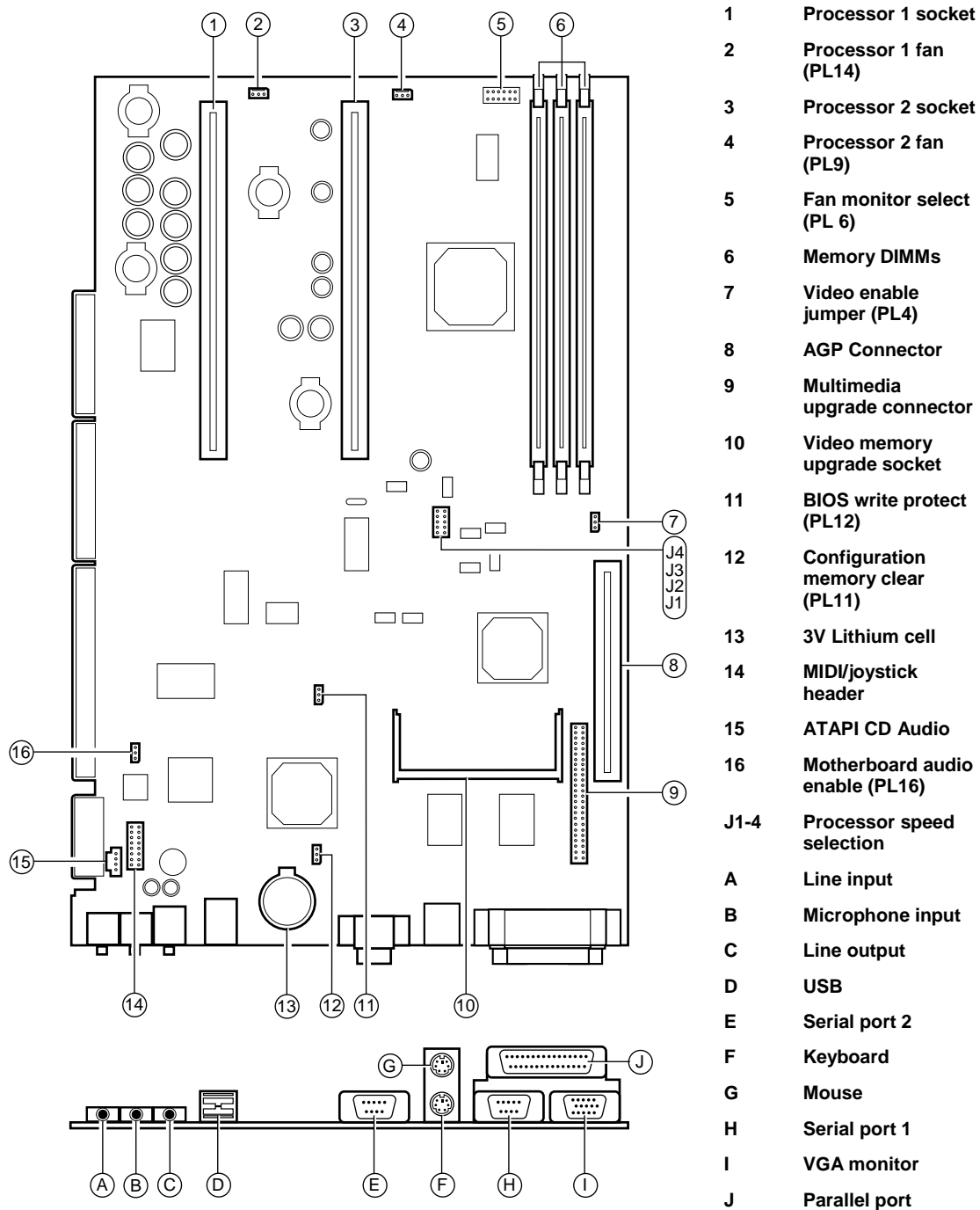

JUMPER DESCRIPTIONS

Processor Core/Bus Ratio – J1-J4

The processor core frequency is determined by multiplying the core bus frequency by the multiplier set by jumpers J1 to J4. J1 is marked with a small triangle. Note some new processors ignore these settings as the ratio is hardwired within the processor.

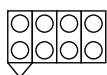

J1 J2 J3 J4

J1	J2	J3	J4	Ratio	Speed at 100MHz
X			X	3.5	350
X	X	X		4.0	400
X		X		4.5	450
X	X			5.0	500
X				5.5	550

X – Jumper fitted

Video enable – PL4

- 1-2 Enable on-board VGA controller
- 2-3 Disable on-board VGA controller

VGA Controller Enabled



VGA Controller Disabled



Motherboard audio enable – PL16

- 1-2 Enable audio CODEC
- 2-3 Disable audio CODEC

Motherboard Audio Enabled



Motherboard Audio Disabled



BIOS Write protect – PL12

- 1-2 Disable BIOS updates
- 2-3 Enable BIOS updates

BIOS Updates Disabled



BIOS Updates Enabled



Configuration (CMOS) memory clear – PL11

(Ensure AC is disconnected from the power supply before moving this jumper. The jumper must be returned to normal position before AC is reconnected)

1-2 Normal operation

2-3 Clear CMOS (power-on)

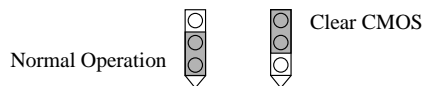

Fan monitor select – PL6

The fan monitor select jumper block configures the two “fan” inputs to the Heceta II system monitor. The pin numbering is shown below, pin 1 being marked by a small triangle.

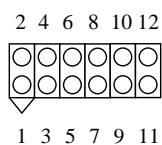

Fan monitor input 1

Select one of the 4 inputs and place a single link across the appropriate pair of pins, eg to monitor CPUtach 2 place the link on pin pair 9-11.

- 1-3 Fantach 1 Tacho fan input 1 from the NLX riser
- 3-5 Fantach 3 Tacho fan input 3 from the NLX riser
- 7-9 Fantach 2 Tacho fan input 2 from the NLX riser
- 9-11 CPUtach 2 Tacho fan input from Processor fan 2 connector (PL9)

Fan monitor input 2

Select one of the 4 inputs and place a single link across the appropriate pair of pins, eg to monitor CPUtach 1 place the link on pin pair 10-12.

- 2-4 Fantach 1 Tacho fan input 1 from the NLX riser
- 4-6 Fantach 3 Tacho fan input 3 from the NLX riser
- 8-10 Fantach 2 Tacho fan input 2 from the NLX riser
- 10-12 CPUtach 1 Tacho fan input from Processor fan 1 connector (PL14)

3 UPGRADING THE MOTHERBOARD

Caution

Care must be taken in the purchase of upgrade parts to ensure both compatibility with the system and the compliance with appropriate approvals and certification, e.g. CE marking within Europe. Using non-approved parts may invalidate your warranty and system approvals.

Upgrading the motherboard is not difficult, but if you do not feel confident about the work involved, you may wish to have your supplier or service organisation complete it for you.

Warning

Never carry out any work inside the computer with AC power applied. Turn off the computer and unplug all power cords before starting work.

ADDING MORE MEMORY

The motherboard has three DIMM (Dual Inline Memory Module) sockets, each of which accepts DIMMs of up to 128 Mbytes, in any combination. The slot furthest from the processors (MM1) should be used first.

DIMM specification

The memory modules must meet the PC100 specification.

Fitting and removing DIMMs

Read all of these instructions through carefully before you start work.

Turn off the computer and unplug all power cords. Take suitable anti-static precautions and remove the system cover. Leave the DIMM in the antistatic packaging until the last possible moment and when you do take the DIMM out of its packaging, hold it by its ends and avoid touching the metal contacts.

Follow the diagrams and simple instructions on the following pages to insert each DIMM.

Afterwards

After you have fitted new modules, check that the system recognises all the memory. If not, check that you have:

- ◆ Correctly fitted the DIMMs in their slots.
- ◆ Installed DIMMs of the correct type.

It may be necessary to refit the original memory to check if there is a problem with your new modules.

Fitting a DIMM

Do not use excessive force. If the module will not fit easily, remove it and start again.

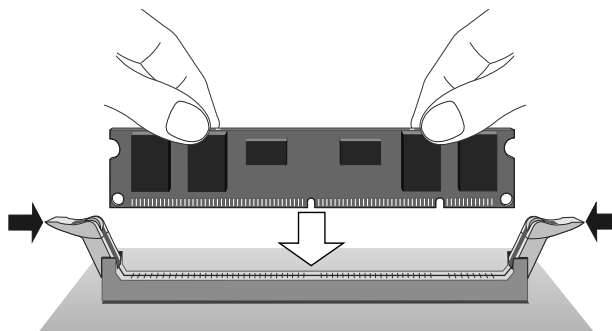

The DIMM is inserted vertically and held in place by the clips at each end.

Removing a DIMM

Do not use excessive force. If the module will not come free easily, check that the holding clips are clear of the module ends.

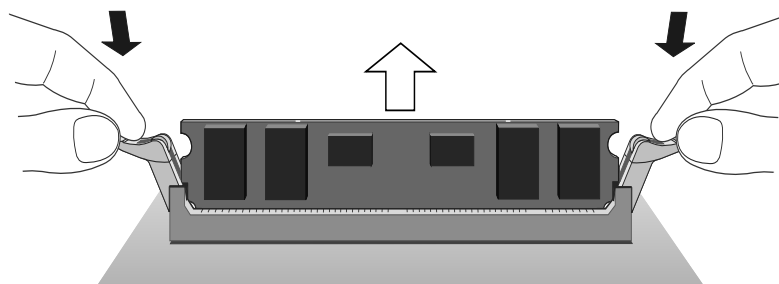

Press the tabs on both of the socket's end clips at the same time. This releases the DIMM and lifts it partly out of the socket.

ADDING MORE VIDEO MEMORY

Video memory is memory reserved for use by the on-board video controller. More video memory can provide more colours or higher resolutions to an extent determined by the capabilities of your monitor.

Check the amount of video memory fitted in your computer. You must fit a module of equal value. For example, if your computer has 2MB of video memory, you must fit a 2MB SODIMM (Small Outline Dual Inline Memory Module).

1. Turn off the computer and unplug all power cords.
2. Take suitable anti-static precautions and remove the system unit cover.
3. Remove any expansion cards that impede access to the video memory upgrade socket (Installation guide reference 10).
4. Unpack the upgrade kit. Hold the SODIMM chip by its edges and be careful not to touch the metal pins.

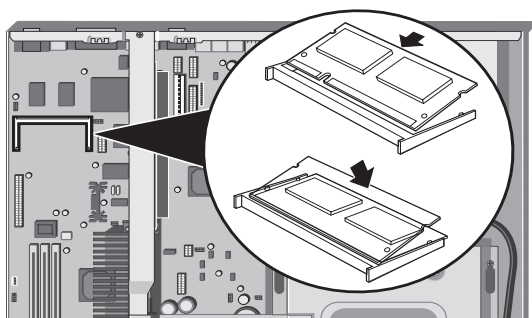

5. Insert the SODIMM into the socket as shown in the illustration.
 6. Replace any expansion cards you removed earlier and refit the system unit cover.
- You can now reconfigure your operating system to use the expanded capabilities of the video controller.

THE PROCESSOR ASSEMBLY

To remove an existing processor

1. Turn off the computer and unplug all power cords. Take suitable anti-static precautions and remove the system cover.
2. If the system was in use just before starting this procedure, the processor **may be hot**, wait until it cools.
3. It may be necessary to remove any expansion cards that obstruct access to the processor.
4. (Processor 2 socket only). See 'A' in the illustration. Carefully squeeze together the grips at both ends (1) of the heatsink support bracket (2) and slide it away.
 - ◇ Some designs of heatsink do not have this bracket fitted.
5. See 'B' in the illustration. Press in the clips (1) at both ends of the top of the processor body to depress the retaining pins out of the vertical supports. Then lift the processor body (2) out of the socket.

Caution

Handle the processor with care, by the body only. Avoid touching the connector at the bottom. Store in an antistatic container.

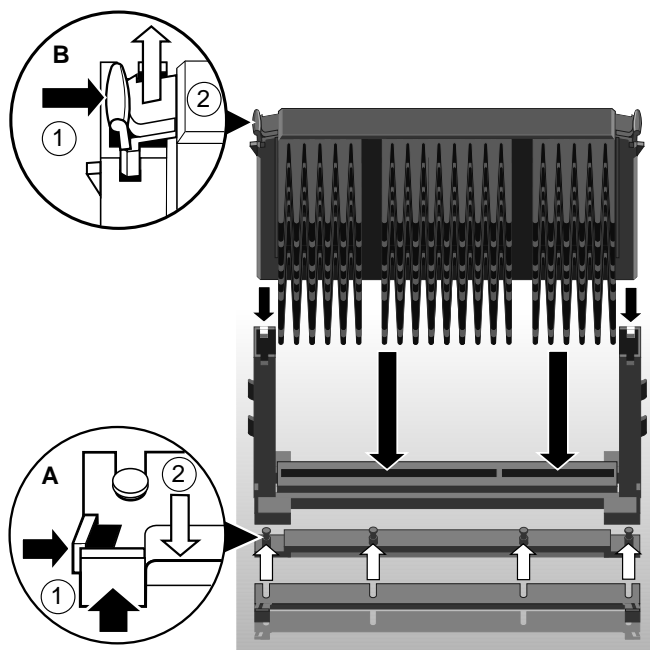

To fit a new processor

1. Take the processor out of its anti-static packaging. Hold the processor by its edges, or its heatsink and *avoid touching the edge connector*.
 - ◇ The upgrade processor and the socket are keyed to ensure that the processor is installed in the correct orientation. It will only fit into the socket one way.
2. Slide the processor into the vertical guides and down into the socket, making sure that it is correctly aligned and that you do not bend or otherwise damage the supports. **Do not use excessive force.**
3. Apply just enough pressure to overcome the resistance offered by the socket. Ensure that the retaining pins snap into the sockets on the end supports.
4. (Processor 2 socket only). Refit the heatsink support, making sure that it is correctly and fully seated on the pins. It should snap into place.
 - ◇ This bracket may not be fitted with some heatsink designs, or may not be needed with the new processor.
5. The upgrade or overdrive processor may have its own cooling fan built into the heatsink. This will have a power lead that will need to be connected to the processor fan power (Installation guide reference 2 for processor 1 and reference 4 for processor 2).
 - ◇ If the fan has only a two-pin connection, ensure it is connected to pins 1 and 2.
6. Now adjust the processor multiplier speed jumpers on the motherboard (Installation guide reference J1-4) in conjunction with the new processor's data sheet.

Warnings

*If two processors are fitted they must be exactly the same type.
If only one processor is fitted the other processor socket must have a terminator card fitted.
The processors require continuous airflow.*

7. Return to their original position any expansion cards that had been removed earlier, then refit and secure the system cover.

REPLACING THE BATTERY FOR THE CONFIGURATION CMOS

The computer keeps a record of its current hardware configuration in a CMOS memory chip, which is sustained by a small battery. This battery has a life of up to 5 years. If you find that you have to reconfigure the computer every time you turn it on, or the date and time seem to be dramatically incorrect, the battery is probably failing and needs to be replaced.

The battery is a 3-volt lithium type (CR2032 or equivalent) typically used in calculators, watches and other small, battery-powered electronic items.

Read carefully the following instructions before commencing work.

1. Turn off the computer and unplug all power cords.

Warning

***Do not** use a metal tool or other conductive implement to remove the battery. If a short-circuit is accidentally made between its positive and negative terminals, it may cause the battery to explode.*

2. Using a **non-conductive** tool, release the latch that holds the battery in place. The battery will pop up allowing you to lift it out of the holder.
3. Taking care not to touch the top or bottom surface of the new battery, pick up the replacement with the positive (+) terminal upwards and press the battery into the holder using a non-conductive implement.
4. Dispose of the old battery in accordance with the battery manufacturer's instructions.

When you next turn on the computer you will have to run the BIOS Setup utility to enter the hardware configuration.

4 ELECTRONICS

PROCESSOR

The TC440 NLX motherboard accepts the following Pentium® II and Pentium® III processors operating at a bus speed of 100MHz.

Processor Speed (MHz)	Core/bus ratio	Bus speed MHz
350	3.5	100
400	4.0	100
450	4.5	100
500	5.0	100
550	5.5	100

The processor core voltages are generated by switched-mode regulators on the motherboard to the Intel VRM8.2 specification. The design meets the 100MHz Slot 1 flexible motherboard recommendations and supports boxed products (processors), including a CPU fan supply.

CORE LOGIC

The core logic is based around the Intel 440BX PCI AGP Controller (PAC) and the PIIX4e multi-function ISA bridge. The features of each are summarised below.

440BX Host bridge

- ◆ Slot1 host bridge
- ◆ DRAM controller supporting SDRAM main memory with optional ECC
- ◆ PCI 2.1 compliant
- ◆ AGP compliant target
- ◆ Virtual PCI to PCI bridge to support AGP bus
- ◆ Packaged in a 492 Pin BGA

PIIX4e Multifunction ISA Bridge

- ◆ PCI to ISA bridge
- ◆ Dual UltraDMA33 IDE controller
- ◆ ISA system peripherals (timers, DMA etc.)
- ◆ Dual USB controller (12Mbps or 1.5Mbps)
- ◆ SMBus controller (motherboard management)
- ◆ Real-time clock
- ◆ ACPI power management logic
- ◆ Packaged in a 324 pin BGA

The two IDE interfaces are completely independent and can operate concurrently. Both can also be configured as a PCI bus master.

Concurrency

The major busses (processor, memory, PCI and AGP) all operate independently to achieve a high degree of concurrency. Most CPU-DRAM and AGP-DRAM transfers can occur concurrently with PCI transfers and so consume no PCI bus bandwidth.

LEVEL 2 CACHE

The second level cache is contained within the processor module. There is no provision for a third level cache.

Cache size is determined by the type of CPU fitted, refer to your CPU manufacturer for this information.

MEMORY

DIMM

There are three DIMM sockets on the motherboards that accept 168-pin un-buffered SDRAM modules to the PC100 memory module specification. All modules must support SPD (serial presence detect) to allow the BIOS to determine the memory configuration and set up the chipset optimally. These modules contain a small EEPROM that describes the module capabilities in detail - including speed, capacity and organisation.

- ◆ 64-bit or 72-bit (ECC) modules.
- ◆ 2 or 4 bank organisation
- ◆ Asymmetric or symmetric memory addressing.
- ◆ Single or double-sided modules.

BIOS

The BIOS is contained in a flash ROM device soldered directly to the motherboard and includes the code listed below. The motherboard will automatically perform a BIOS recovery operation if it detects a valid recovery disk during the boot sequence. An override jumper that prevents all writes (recovery or update) provides update protection. The BIOS ROM is accessed as a single linear region in the memory space from 4GB-128kB (0FFFE0000 - 0FFFFFFFh) and copied at the top of ISA memory (0E0000 - 0FFFFFFh).

- ◆ Core motherboard BIOS
- ◆ VGA BIOS (ATI RAGE PRO or RAGE IIC)
- ◆ USB, including legacy support
- ◆ DMI
- ◆ Setup-in-ROM
- ◆ Intel Pentium® II and Pentium® III microcode update support and code
- ◆ Power and system management code

VIDEO

VGA Controller

The VGA controller is an ATI Rage Pro or ATI Rage IIC device packaged in a 256 ball BGA. Video memory is via 2 SGRAM devices mounted on the motherboard (to give 2MB or 4MB) and an SODIMM connector that accepts SGRAM modules (2MB or 4MB extra). The VGA controller can be disabled via a motherboard jumper. It also provides an I²C bus to access other video features. The VGA controller has the following features.

- ◆ AGP compliant to 133MHz (66MHz option).
- ◆ 230MHz integrated RAMDAC.
- ◆ 100MHz 64-bit SGRAM video memory (800MBps).
- ◆ DDC1, DDC2B, DPMS and Energy Star.
- ◆ 2D acceleration.
- ◆ 3D acceleration with triangle setup engine and texture cache (Rage Pro only).
- ◆ Motion video acceleration with MPEG2 assist.
- ◆ Multimedia channel for upgrades (AMC connector).

The allowable memory upgrade paths are shown in the table below. The entries are the total memory capacity available by fitting 2MB or 4MB modules.

<i>Motherboard Memory¹</i>	<i>2MB SODIMM</i>	<i>4MB SODIMM²</i>
0MB	2MB	4MB
2MB	4MB	
4MB		8MB

The amount of video memory fitted to the motherboard is automatically detected by the BIOS. Video memory upgrade modules do not require an SPD ROM.

¹ 2MB builds are based on 8Mb devices. 4MB builds use 16Mb devices.

² 4MB modules must be based on 16Mb devices.

2D Display modes and maximum frame rates³

	256 colours	65536 colours		16.7M colours	
	2MB	2MB	4MB	2MB	4MB
640 x 480	200	200	200	200	200
800 x 600	200	200	200	160	160
1024 x 768	150	150	150		120
1152 x 864	120	120	120		85
1280 x 1024	100		100		85
1600 x 1200	76		76		

Frame Buffer MB	Screen Resolution	Colour Depth Bits/pixel	Display Buffer⁴ MB	Z Buffer	Texture Memory⁵ MB
2	512 x 384	16	0.38 x 2	0.38	0.88
2	640 x 480	16	0.59 x 2	0.59	0.24
4	640 x 480	16	0.59 x 2	0.59	2.24
4	640 x 480	32	1.17 x 2	0.59	1.07
4	800 x 600	16	0.92 x 2	0.92	1.25
8	1024 x 768	32	3.00 x 2	1.50	0.50
8	1280 x 1024	16	2.50 x 2	2.50	0.50

AGP

The Accelerated Graphics Port (AGP) is a hardware interconnect designed to improve the performance of 3D graphics displays. The specification is based on PCI but is point-to-point and provides for data rates over 500MBps. The implementation on this motherboard is a private (three load) local bus between the chipset, the Rage Pro video controller and the AGP connector.

When a Rage Pro device or AGP card is fitted the bus can operate in 1X or 2X modes as defined by the AGP specification. Fitting an AGP card to the AGP connector requires the on board video to be disabled via the jumper.

When a Rage IIC device is fitted the interface between the 443BX North Bridge and the VGA controller operates as a 66MHz PCI bus and no AGP signalling occurs.

Two levels of performance gain are achieved:

- ◆ 2D Operation. Since the AGP operates at 66MHz, twice the data rate of the PCI bus is available to normal video traffic.

³ These are the primary display modes. Others are available.

⁴ Front and back buffers.

⁵ Main memory can be used for additional texture storage via AGP.

- ◆ 3D Operation (Rage Pro only). Address translation logic and 133MHz bus mastering allows the video controller to maintain texture information in main memory - reducing the need for a large frame buffer.

AUDIO

The audio subsystem is based around an ESS Solo1 CODEC. The audio subsystem can be completely depopulated at build time to leave the standard PC beep function.

ESS Solo 1

- ◆ SoundBlaster™ Pro register-level compatible
- ◆ PCI bus interface
- ◆ Internal FM synthesiser
- ◆ Dual DMA support with FIFO & full duplex operation
- ◆ Programmable power management
- ◆ Joystick and MPU-401 compatible MIDI interfaces
- ◆ 5 channel input mixer

One power amplifier is used - a National Semiconductor LM4880 'Boomer' to drive the LINE-out jack socket and the optional internal speaker (via the NLX riser). The microphone input provides power to enable condenser microphones to be used.

Channel	
CODEC LINE	Rear line input jack socket
CODEC AUX A	CD input (from riser) or from motherboard connector
CODEC AUX B	VGA AMC Connector
CODEC MIC	Rear microphone jack socket or Riser connection
CODEC Mono In	Modem in audio from Riser

The following audio connectors are supported.

- ◆ Rear 3.5mm jack microphone input with phantom power
- ◆ Rear 3.5mm jack LINE in
- ◆ Rear 3.5mm jack LINE out
- ◆ Internal CD-ROM stereo audio on 4-pin ATAPI connector
- ◆ AMC connector stereo audio
- ◆ Modem audio via NLX riser auxiliary edge connections

REAL TIME CLOCK

The real time clock is located in the PIIX4e and includes 256 bytes of battery backed RAM with two lockable ranges. The clock includes a date alarm and operates from a 32.768kHz crystal. The 3V lithium cell provides data retention for up to 5 years of normal use. Note that the battery is used only when AC power is not applied to the system (or a standby 5V rail is not provided).

STANDARD I/O

The Nat Semi PC87351 SUPER IO controller provides standard I/O. This comprises the four functions described below. It is packaged in a 128-pin PQFP and is PC98 and ACPI compliant.

Keyboard and Mouse

The keyboard and mouse controller uses the Phoenix Multikey version 1.40 firmware. PS/2 style keyboard and mouse ports are provided on the rear panel. The ports are interchangeable.

Floppy Disk Interface

Standard 2-mode and 3-mode 3½" drives are supported.

The floppy disk drive signals are routed from the motherboard to the NLX riser and the floppy disk drive connector is mounted on the NLX riser.

As per the NLX specification, all floppy disk input signals to the motherboard must be pulled up on the NLX riser.

Serial Ports

There are two standard COM ports, which are wired to two standard 9-way D-type connectors on the rear panel. The maximum Baud rate is 115K bits per second.

Parallel Port

This is EPP 1.7/1.9 and IEE1284 (ECP) compliant and is compatible with a standard (output only) PC parallel port as well as a bi-directional (PS/2 style) parallel port. There is a 25-way D-type connector on the rear panel.

ADDITIONAL I/O

IDE Disk Controller

Two UltraDMA33 IDE ports are provided with the controller integrated into the PIIX4e. This allows for a maximum of four drives to be connected - two to each port. Normally the primary port would be used for hard disk drives and the secondary port for CD-ROM or DVD drives. 120MB floppy drives have IDE interfaces.

Both IDE controllers are independent and both can bus-master data into memory for improved performance. UltraDMA33 drives have a theoretical maximum transfer rate of 33MBs⁻¹. The interfaces are also, of course, compatible with standard ATA drives.

Universal Serial Bus (USB)

The motherboard supports two USB ports with the controller integrated into the PIIX4e. The motherboard has a build option of a dual USB connector at the rear or with a single on the rear and with the second port routed to the NLX riser to cater for an optional front USB connector. The standard build is with a dual USB connector at the rear.

SECURITY

There is chassis intrusion detection available on motherboards with the Heceta II fitted. This is capable of detecting an intrusion even when AC is disconnected (the logic is powered from the 3V lithium cell).

MOTHERBOARD POWER

Processor Power

Two independent voltage regulators conforming to the Intel VRM8.2 standard supply power for the processor cores. The motherboard automatically selects the correct processor voltage.

Battery

An IEC-type CR2032 3V lithium coin cell and holder are fitted to the board. Note that when the motherboard is powered off but the AC remains connected (the standby rail is active) the battery is not used.

POWER MANAGEMENT

Standby Switch

The motherboard supports an ACPI-compliant standby switch for use with a soft-switch power supply. The action of the switch is under a combination of hardware and software control and is summarised in the table below. The motherboard will power off regardless of the state of software if the switch is held down for more than 4 seconds.

State	Action after switch pressed
Standby (soft power off)	Machine powers up and executes POST
POST, DOS or APM O/S	Machine powers off into standby state

Behaviour After AC-Disconnect

The 'Wake on AC connect' BIOS option and the state of the lithium cell determine the behaviour of the motherboard after an AC-disconnect. The table below describes this.

Conditions	Action on AC Reconnect
CMOS RAM cleared. This is the state of a new motherboard before assembly. This also occurs after battery removal or failure.	Motherboard waits for standby switch to be pressed.
CMOS RAM not cleared and 'Wake on AC connect' was set to 'Enabled'.	Motherboard fully powers up without intervention.
CMOS RAM not cleared and 'Wake on AC connect' was set to 'Disabled'. This is the default state. Resume events will be lost if an AC power failure occurs.	Motherboard waits for standby switch to be pressed.

Sleep State Indication

Indication of system activity states is provided by the signal 'STANDBY_LED#' to the NLX riser (pin B159). If this signal is asserted (low) then the system is in a power-managed state. The implementation of coloured LEDs to indicate system power states is dependent on the NLX riser used.

SYSTEM MANAGEMENT

There are three main elements to the system management hardware.

- ◆ A Heceta II system monitor
- ◆ The PIIX4e power management devices 9 and 10
- ◆ Processor thermal diode ADCs

Heceta II System Monitor

The Heceta II provides the system monitor functions as described below and is accessed via the PIIX4e SMBus interface. It provides the following functions.

- ◆ Fan monitoring. The two inputs to the Heceta II device can be configured to monitor any two of the five “fantach” signals. The configuration of these inputs is via the fan monitor select jumpers (installation guide reference 5). “Fan 1” input to the Heceta II can monitor any of the three fantach signals fed from the NLX riser or the fantach signal from the processor 1 fan connector. “Fan 2” input to the Heceta II can monitor any of the three fantach signals fed from the NLX riser or the fantach signal from the processor 2 fan connector.
- ◆ Monitoring of system +12V, +5V, +3.3V, CPU core, -12V and 2.5V power rails
- ◆ Monitoring of system temperature (actually the motherboard surface temperature)
- ◆ Monitoring of chassis intrusion (top cover)

FAN CONTROL

The NLX system fan is controlled by the motherboard such that it stops rotating when the system is in ‘Suspend’ mode. As a build option, the TC440 NLX motherboard supports variable fan speed control in which the speed of the fan is raised as the temperature of the processor increases. This considerably reduces fan noise in normal operation.

The variable fan speed option can only be used with an ACPI-aware operating system (such as Windows® 98) and a 100MHz-bus Pentium® II or Pentium® III processor.

EXPANSION SLOTS

The ISA and PCI expansion slots are located on the riser card. The ISA and PCI signals are routed through an edge connector on one edge of the board which mates with the NLX riser.

As per the NLX specification, the motherboard requires that the PCI signals are correctly terminated and pulled up on the NLX riser for the motherboard to operate properly.

Industry Standard Architecture (ISA)

A maximum of 5 ISA slots is supported via the NLX riser.

Peripheral Component Interconnect (PCI)

A maximum of 4 PCI cards is supported via the NLX riser, each with bus master support.

BUS RESOURCE UTILISATION

ISA DMA Channels

DMA	Data Width	Usual Assignment	Audio
0	8-bit	ISA card	option
1	8-bit	ISA card	default 8-bit
2	8-bit	Floppy disk controller	
3	8-bit	ECP parallel port	option
4	-	DMAC daisy chain	
5	16-bit	ISA card	
6	16-bit	ISA card	
7	16-bit	ISA card	

Shaded areas indicate DMA channels not normally available on the ISA bus

ISA Interrupts

IRQ	Usual Assignment	Fixed Assignment?	PCI
IRQ0	System timer	YES	
IRQ1	Keyboard	NO	
IRQ2	IRQ8 - 15 Cascade	YES	
IRQ3	Serial port 2	NO	X
IRQ4	Serial port 1	NO	X
IRQ5	ISA/PCI bus (Audio)	NO	X
IRQ6	Floppy disk	NO	X
IRQ7	Parallel port	NO	X
IRQ8	Real time clock	NO	
IRQ9	ISA/PCI bus		X
IRQ10	ISA/PCI bus		X
IRQ11	ISA/PCI bus		X
IRQ12	PS/2 Mouse	NO	X
IRQ13	Floating point error	YES	
IRQ14	Primary hard disk	If drive connected	X
IRQ15	Secondary hard disk	NO	X

The last column indicates which ISA interrupts PCI devices can be routed to.

PCI Interrupts

Channel	Device
INTA#	Slots
INTB#	Slots
INTC#	Audio & Slots
INTD#	Video & slots

PCI Device Selection (motherboard devices)

Bus number	Device number (decimal)	Function number	Address line	Function
0	0	0	11	Host bridge
0	1	0	12	PCI to PCI bridge
0	6	0	17	PCI Audio CODEC
0	7	0	18	South bridge
0	7	1	18	IDE controller
0	7	2	18	USB controller
0	7	3	18	Power management & Smbus controllers
1	0 ⁶	0	16	AGP video controller

PCI Arbitration

PIIX4e request level	Bus	Function
0	0	PCI slot 1
1	0	PCI slot 2
2	0	PCI slot 3
3	0	PCI slot 4
4	0	PCI audio CODEC

Note that the arbiter implements a round robin scheme and thus no request level has fixed priority over another. The AGP video controller does not consume any PCI bandwidth and competes for memory resource independently.

⁶ PCI to PCI bridges translate address lines from AD16. The host bridge translates address lines from AD11.

5 BIOS SETUP & POST

BIOS (pronounced “bye-oss”) stands for ‘basic input/output system’. The BIOS mediates between the computer’s hardware – the processor, memory, and so on – and its software – the operating system and your programs. The BIOS program is kept in permanent, read-only memory or ROM (although if necessary it can be upgraded by an authorised maintainer).

BIOS Setup is a helpful utility that forms part of the BIOS program. It allows you to view and alter the computer’s hardware configuration. It is also used to configure various security and power-saving options. Configuring the computer is necessary to ensure that the software you use can recognise and exploit the hardware’s capabilities.

The current configuration is kept in a special area of memory, called CMOS memory, and maintained by a battery so that the configuration is preserved even while the computer is switched off.

Whenever the computer is turned on, the BIOS power-on self-test (POST) routine tests various hardware components, including memory, and compares the actual configuration of the computer with that recorded in permanent (CMOS) memory.

A configuration discrepancy could arise if you have just installed or removed a hardware option (for example, if you have added or replaced an expansion card).

BIOS SETUP

To start the BIOS Setup utility:

1. Turn on or restart your computer.
2. When you see
‘Press <F2> to enter setup’
appear on the screen, press the F2 key.
3. If you have previously defined a Supervisor password, you are prompted for it before BIOS Setup starts.

Control keys

Use the keys listed in the legend bar at the bottom of the BIOS Setup screen to make your selections or exit the current menu.

Sub-menus are marked by a ► pointer. To display a sub-menu, use the arrow keys to move the cursor to the sub-menu you want, then press ENTER.

Changeable fields are enclosed in square brackets. To select an item, use the arrow keys to move the cursor to the field you want. Then use the PLUS (+) and MINUS (–) keys to select a value for that field.

Press	To
F1 or Alt-h	View a general help topic. Press esc to close the help window.
Esc	Exit the current menu.
Left or Right arrow	Select a different menu.
Up or Down arrow	Select fields on the current menu.
Plus (+) or F6 or Spacebar	Select the next value for the current field.

Press	To
Minus (-) or F5	Select the previous value for the current field.
Enter	Make a selection from the menu bar or enter a sub-menu.
Home or End	Move the cursor to the top or bottom of the current menu.
Page up or Page down	Move the cursor to the next or previous page of the current menu.
F9	Restore the default settings for the fields on the current menu.
F10	Save the changes you've made and exit from BIOS Setup.

Caution

The default BIOS settings may not be appropriate for your particular system. Make a note of the current settings before pressing F9 or using the Load Setup Defaults option of the Exit menu.

Getting help in BIOS Setup

You can at any time get general help about the control keys by pressing the F1 key.

The help window on the right-hand side of each menu displays help text for the currently-selected field. It changes as you move the cursor from one field to another.

Reserving ISA legacy resources

To reserve interrupts and upper memory block (UMB) regions for ISA expansion cards, go to the **Advanced** menu, select **PCI Configuration**, then select **PCI/PNP ISA IRQ Resource Exclusion** or **PCI/PNP ISA UMB Region Exclusion** as required.

MULTI-BOOT FACILITY

Immediately after the first screen, a second screen displays various POST messages such as the memory test. While this screen is on display, a message at the bottom says: 'Press <F2> to enter setup or <ESC> to enter Boot Menu'. Even if this message is not displayed, you can press the <ESC> key and this menu will appear just before booting:

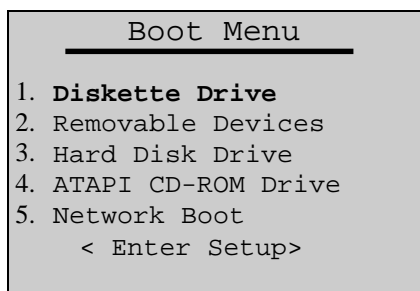

This menu can be used to temporarily use another drive or device to boot your system, for example a bootable CD-ROM, without having to enter the BIOS setup. Simply use the up and down arrows to make a selection. This change will not be permanent and the system boot will revert to the normal BIOS setting the next time you switch on your system.

POWER-ON SELF-TEST

Recoverable POST errors

Whenever a recoverable (non-terminal) error occurs during POST, the BIOS displays an error message describing the problem (the most usual are described below). After some messages, you may be prompted to **Press <F1> to resume, <F2> to enter Setup** or just **Press <F2> to enter Setup**.

In general, you should respond to these errors as follows:

- ◆ Shut down the computer, wait 20 to 30 seconds, and then turn it on again to see if the problem is still reported.
- ◆ Check that all external cables are securely connected.
- ◆ Try running the BIOS Setup utility to reconfigure the system. If the computer will not BOOT after you make changes in BIOS Setup, try returning to the original settings.
- ◆ Open up the system unit and check that all internal signal and power cables are securely connected.
- ◆ If the problem persists, contact your supplier or authorised maintainer.

System Configuration Data updated

This message indicates that the system configuration has changed (such as an expansion card has been added) and that the configuration data has therefore been updated.

System Configuration Data Write Error

This message indicates that the system configuration has changed (such as an expansion card has been added) but the configuration data could not be updated. This is normally caused by the BIOS program enable jumper being in the disable position. For configuration changes to be correctly recorded the jumper must be in the enable position.

Invalid System Configuration Data – run configuration utility

The data describing the system configuration is incorrect and should be updated. This can be done by checking the 'Reset Configuration Data' in BIOS Setup followed by 'Save and Exit'.

Diskette drive A error

Drive A: is present but fails the POST diskette tests. Check that the drive is defined correctly in BIOS Setup. If necessary, open the system unit and check that the drive's signal (ribbon) cable is connected.

System/Extended/Shadow RAM failed at offset: xxxx Failing bits: yyyy

System, extended or shadow memory is not working, or not configured properly, at offset xxxx. The hexadecimal number yyyy is a map of the bits at the address that failed the memory test. Each "1" in the map represents a failed bit.

Fixed disk X failure or Fixed disk controller failure

A fixed (hard) disk drive is not working or not configured properly. Check that the drive is defined correctly in BIOS Setup. If necessary, open the system unit and check that the drive's signal (ribbon) cable is connected.

Incorrect drive A type - run SETUP

The diskette drive is not correctly specified in BIOS Setup.

Invalid NVRAM media type

Problem with NVRAM (non-volatile random-access memory).

Keyboard error [nn] or Keyboard controller error

There is a problem with the keyboard or (less likely) the standard I/O controller on the motherboard. If POST discovers a stuck key it displays its scan code.

Operating system not found

An operating system cannot be located either on a system diskette or on a hard disk. Start BIOS Setup and check that the diskette and/or hard disk drives are specified correctly.

Parity check 1 xxxx or Parity check 2 xxxx

Parity error found on the system (1) or I/O (2) bus. The BIOS attempts to locate and display the address xxxx. If it cannot locate the address, it displays "????".

Previous boot incomplete - default configuration used

The previous POST did not complete successfully. POST loads default values and offers to start BIOS Setup. If the failure was caused by incorrect values and they are not corrected, the next boot will likely fail too.

Real-time clock error

Enter BIOS Setup and check the System Time and System Date settings on the Main menu.

System battery is dead - replace and run Setup

Replace the configuration battery as instructed in the previous chapter, then use BIOS Setup to reconfigure the system.

System cache error - cache disabled

The RAM cache failed POST and BIOS disabled it.

System CMOS checksum bad - run Setup

System CMOS has been corrupted or modified incorrectly, perhaps by an application program that changes data stored in CMOS. Run BIOS Setup and reconfigure the system either by getting the default values or by making your own selections.

Terminal POST errors and beep codes

There are several POST routines that shut down the computer if they fail. If possible, the BIOS sounds a sequence of beeps to identify the point at which POST failed. The most usual errors are listed below.

The BIOS also issues one long tone followed by two short tones if the video system is faulty or if an external ROM module (including video ROM) fails.

Turn off the computer for 30 seconds and then try again. If the fault persists, make a note of the error code (if any) and call your supplier or authorised maintainer.

Beeps	Test which failed
1-2-2-3	BIOS ROM checksum
1-3-1-1	DRAM refresh.
1-3-1-3	8742 keyboard controller
1-3-4-1	RAM failure on address line.
1-3-4-3	RAM failure on data bits of low byte of memory bus.
1-4-1-1	RAM failure on data bits of high byte of memory bus.
2-1-2-3	Check ROM copyright notice
2-2-3-1	Test for unexpected interrupts
1-2	Video configuration failure, or option ROM checksum failure. (One long, two short beeps.)

The BIOS also issues Port 80h codes that can be displayed using a suitable diagnostic card. The codes can be used to determine the failure.

Code	POST Routine Description
02h	Verify Real Mode
03h	Disable Non-Maskable Interrupt (NMI)
04h	Get CPU type
06h	Initialise system hardware
08h	Initialise chipset with initial POST values
09h	Set IN POST flag
0Ah	Initialise CPU registers
0Bh	Enable CPU cache
0Ch	Initialise caches to initial POST values
0Eh	Initialise I/ O component
0Fh	Initialise the local bus IDE
10h	Initialise Power Management
11h	Load alternate registers with initial POST values
12h	Restore CPU control word during warm boot
13h	Initialise PCI Bus Mastering devices
14h	Initialise keyboard controller
16h	BIOS ROM checksum
17h	Initialise cache before memory autosize
18h	8254 timer initialisation
1Ah	8237 DMA controller initialisation
1Ch	Reset Programmable Interrupt Controller
20h	Test DRAM refresh
22h	Test 8742 Keyboard Controller
24h	Set ES segment register to 4 GB
26h	Enable A20 line
28h	Autosize DRAM
29h	Initialise POST Memory Manager
2Ah	Clear 512 KB base RAM
2Ch	RAM failure on address line
2Eh	RAM failure on data bits of low byte of memory bus
2Fh	Enable cache before system BIOS shadow
30h	RAM failure on data bits of high byte of memory bus
32h	Test CPU bus- clock frequency
33h	Initialise Phoenix Dispatch Manager
34h	Test CMOS RAM
35h	Initialise alternate chipset registers.

Code	POST Routine Description
36h	Warm start shut down
37h	Reinitialise the chipset (MB only)
38h	Shadow system BIOS ROM
39h	Reinitialise the cache (MB only)
3Ah	Autosize cache
3Ch	Advanced configuration of chipset registers
3Dh	Load alternate registers with CMOS values
42h	Initialise interrupt vectors
44h	Initialise BIOS interrupts
45h	POST device initialisation
46h	Check ROM copyright notice
48h	Check video configuration against CMOS
49h	Initialise PCI bus and devices
4Ah	Initialise all video adapters in system
4Bh	Display QuietBoot screen
4Ch	Shadow video BIOS ROM
4Eh	Display BIOS copyright notice
50h	Display CPU type and speed
51h	Initialise EISA board
52h	Test keyboard
54h	Set key click if enabled
56h	Enable keyboard
58h	Test for unexpected interrupts
59h	Initialise POST display service
5Ah	Display prompt "Press F2 to enter SETUP"
5Bh	Disable CPU cache
5Ch	Test RAM between 512 and 640 KB
5Eh	Base address
60h	Test extended memory
62h	Test extended memory address lines
64h	Jump to UserPatch1
66h	Configure advanced cache registers
67h	Initialise Multi Processor APIC
68h	Enable external and CPU caches
69h	Setup System Management Mode (SMM) area
6Ah	Display external L2 cache size
6Bh	Customise defaults
6Ch	Display shadow- area message
6Eh	Display possible high address for UMB recovery

Code	POST Routine Description
70h	Display error messages
72h	Check for configuration errors
74h	Test real- time clock
76h	Check for keyboard errors
77h	SMBus init devices
78h	Initialise system monitor and check for intrusion
79h	PCI audio init
7Ah	Test for key lock on
7Ch	Set up hardware interrupt vectors
7Eh	Initialise coprocessor if present
80h	Disable onboard Super I/ O ports and IRQs
81h	Late POST device initialisation
82h	Detect and install external RS232 ports
83h	Configure non- MCD IDE controllers
84h	Detect and install external parallel ports
85h	Initialise PC- compatible PnP ISA devices
86h	Re- initialise onboard I/ O ports.
87h	Configure Motheboard Configurable Devices
88h	Initialise BIOS Data Area
89h	Enable Non- Maskable Interrupts (NMIs)
8Ah	Initialise Extended BIOS Data Area
8Bh	Test and initialise PS/ 2 mouse
8Ch	Initialise floppy controller
8Eh	Autotype
8Fh	Determine number of ATA drives
90h	Initialise hard- disk controllers
91h	Initialise local- bus hard- disk controllers
92h	Jump to UserPatch2
93h	Build MPTABLE for multi- processor boards
95h	Install CD ROM for boot
96h	Clear huge ES segment register
97h	Fixup Multi Processor table
98h	Search for option ROMs. One long two short beeps on checksum failure
99h	Check for SMART Drive
9Ah	Shadow option ROMs
9Ch	Set up Power Management
9Dh	Security init
9Eh	Enable hardware interrupts
9Fh	Determine number of ATA and SCSI drives

Code	POST Routine Description
A0h	Set time of day
A2h	Check key lock
A4h	Initialise typematic rate
A8h	Erase F2 prompt
AAh	Scan for F2 key stroke
ACh	Enter SETUP
A Eh	Clear IN POST flag
B0h	Check for errors
B1h	ROMPilot unload
B2h	POST done - prepare to boot operating system
B4h	One short beep before boot
B5h	Terminate QuietBoot
B6h	Check password (optional)
B7h	ACPI initialisation
B8h	Clear global descriptor table
B9h	Clean up all graphics
BAh	Initialise DMI parameters
BBh	Initialise PnP Option ROMs
BCh	Clear parity checkers
BDh	Display MultiBoot menu
BEh	Clear screen (optional)
BFh	Check virus and backup reminders
C0h	Try to boot with INT 19
C1h	Initialise POST Error Manager (PEM)
C2h	Initialise error logging
C3h	Initialise error display function
C4h	Initialise system error handler
C5h	Dual cmos init
C6h	Dock init
C7h	Dock init late
C8h	Force recovery check
C9h	Extended checksum check of bios
D2h	Unknown\unexpected interrupt
E0h	Initialise the chipset
E1h	Initialise the bridge
E2h	Initialise the CPU
E3h	Initialise system timer
E4h	Initialise system I/ O
E5h	Check force recovery boot

<i>Code</i>	<i>POST Routine Description</i>
E6h	Checksum BIOS ROM
E7h	Go to BIOS
E8h	Initialise Multi Processor
E9h	Set Huge Segment
EAh	Initialilze OEM special code
EBh	Initialise PIC and DMA
ECh	Initialise Memory type
EDh	Initialise Memory size
EEh	Shadow Boot Block
EFh	System memory test
F0h	Initialise interrupt vectors
F1h	Initialise Run Time Clock
F2h	Initialise video
F3h	Initialise beeper
F4h	Initialise boot
F5h	Clear Huge segment
F6h	Boot to Mini DOS
F7h	Boot to Full DOS

The following codes are produced during the BIOS recovery sequence.

<i>Code</i>	<i>POST Routine Description</i>
14h	Read file
16h	Erase sector
17h	Program sector
18h	Verify sector
E0h	Memory allocation error
E1h	File not found
E2h	Path not found
E3h	No handles available
E4h	Access denied
E5h	Invalid access code
E6h	Undefined file open error
E7h	Access denied on file read
E8h	Invalid handle
E9h	Undefined file read error
EAh	File close failure
EBh	Chip ID failure
ECh	Sector erase failure
EDh	Sector protect failure
EEh	Sector program failure
EFh	Sector verify error
88h	Video not found
FFh	Incorrect parameters

6 ELECTRICAL

POWER REQUIREMENTS

The motherboard power requirements are heavily dependent on system configuration and the software being used. The table below can be used as a guide to the likely power supply requirements. They are measured using two 400MHz Intel Pentium® II Processors, 3 memory modules and 8MB video memory running stress test software designed to yield worst case results. They should not, however, be regarded as maximum values.

Supply	+5V standby	+5V	+3.3V	+12V	-12V	-5V
Voltage Tolerance	± 5%	± 5%	± 4%	± 5%	± 5%	± 5%
Maximum Current	20mA	10A	3A	300mA	100mA	100mA

This motherboard requires a +5V standby supply to operate correctly. This is normally provided by an NLX-compatible power supply via the riser.

Advisory

Mitsubishi has found that some power supplies generate damaging voltages on their main outputs when their +5V standby output is over-loaded.

PCB

The PCB is a four-layer design measuring W9.0" x L13.6". It is NLX compatible. The inner power planes are arranged so that the ground plane is nearest the top component layer.

The PCB has a UL flammability rating of 94V-0.

7 CONNECTOR ASSIGNMENTS

Keyboard and Mouse (PS/2 Mini-DIN)

(Installation guide references F and G)

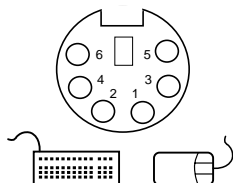

Pin	Signal	Direction	Description
1	CLK	I/O	Data clock
2	VCC	O	+5V Power
3	GND	-	Signal ground
4	NC	-	No connect
5	DATA	I/O	Serial data
6	NC	-	No connect

Serial Port 1 and Serial Port 2 (9 way D-type)

(Installation guide references E and H)

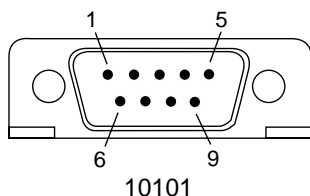

Pin	Signal	Direction	Description
1	DCD	I	Data Carrier Detect
2	RXD	I	Receive Data
3	TXD	O	Transmit Data
4	DTR	O	Data Terminal Ready
5	GND	I	Signal ground
6	DSR	I	Data Set Ready
7	RTS	O	Request to Send
8	CTS	I	Clear to Send
9	RI	I	Ring Indicate

Parallel Port (25 way D-type)

(Installation guide reference J)

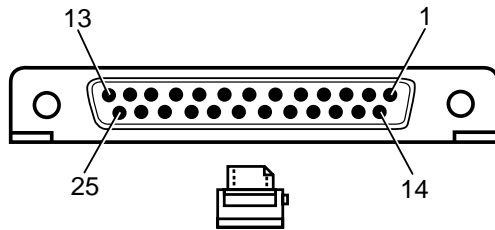

Pin	Standard mode	ECP mode	Direction
1	STB#	STB#	
2	DATA0	DATA0	I/O
3	DATA1	DATA1	I/O
4	DATA2	DATA2	I/O
5	DATA3	DATA3	I/O
6	DATA4	DATA4	I/O
7	DATA5	DATA5	I/O
8	DATA6	DATA6	I/O
9	DATA7	DATA7	I/O
10	ACK#	ACK#	I
11	BUSY	BUSY	I
12	PE	PE	I
13	SLCT	SLCT	I
14	AFD#	AFD#	O
15	ERR#	ERR#	I
16	INIT#	INIT#	O
17	SLIN#	SLIN#	O
18	GND	GND	-
19	GND	GND	-
20	GND	GND	-
21	GND	GND	-
22	GND	GND	-
23	GND	GND	-
24	GND	GND	-
25	GND	GND	-

VGA (15 way high density D-type)

(Installation guide reference I)

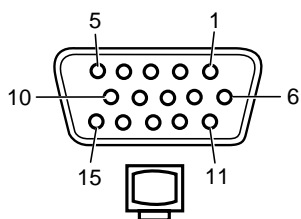

Pin	Signal	Pin	Signal
1	Red	9	+5V Power (fused)
2	Green	10	GND
3	Blue	11	No Connect
4	No Connect	12	Monitor ID 1
5	GND	13	HSYNC
6	Red Return	14	VSYNC
7	Green Return	15	Monitor ID 3
8	Blue Return		

USB Ports 0 and 1 (USB port 1 on the rear panel is an option)

(Installation guide reference D)

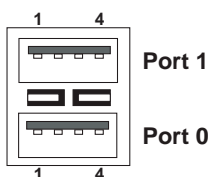

Pin	Signal	Direction	Description
1	VCC	O	+5V Power fused
2	DATA-	I/O	Differential Serial Data -
3	DATA+	I/O	Differential Serial Data +
4	GND	-	Signal ground

Line Input and Output (3.5mm stereo jack)

(Installation guide references A and C)

Pin	Signal
Sleeve	GND
Tip	Left channel
Ring	Right channel

Microphone Input (3.5mm stereo jack)

(Installation guide reference B)

<i>Pin</i>	<i>Signal</i>
Sleeve	GND
Tip	Mono input
Ring	Electret bias voltage

Processor Fan (3 way header with locking ramp)

(Installation guide reference 2 and 4)

<i>Pin</i>	<i>Signal</i>	<i>Direction</i>	<i>Description</i>
1	GND	-	Signal ground
2	+12V Power	O	DC fan drive voltage
3	FAN_TACH#	I	Tacho sense from fan

Internal CD audio (4 way ATAPI header)

(Installation guide reference 15)

<i>Pin</i>	<i>Signal</i>	<i>Direction</i>	<i>Description</i>
1	LEFT	I	Left audio input
2	GND	-	Signal ground
3	GND	-	Signal ground
4	RIGHT	I	Right audio input

MIDI/Joystick (16 way dual row header)

(Installation guide reference 14)

<i>Pin</i>	<i>Signal</i>	<i>Pin</i>	<i>Signal</i>
1	+5V Power fused	2	+5V Power fused
3	JAB1	4	JBB1
5	JACX	6	JBCX
7	GND	8	MIDI OUT
9	GND	10	JBCY
11	JACY	12	JBB2
13	JAB2	14	MIDI IN
15	+5V Power	16	Key

VESA/AMCC Support (40 way dual row header)

(Installation guide reference 9)

<i>Pin</i>	<i>Signal</i>	<i>Pin</i>	<i>Signal</i>
1	Digital GND	2	PIXEL DATA0
3	Digital GND	4	PIXEL DATA1
5	Digital GND	6	PIXEL DATA2
7	EVIDEO	8	PIXEL DATA3
9	ESYNC	10	PIXEL DATA4
11	EDCLK	12	PIXEL DATA5
13	SAD4	14	PIXEL DATA6
15	Digital GND	16	PIXEL DATA7
17	Digital GND	18	DCLK
19	Digital GND	20	SAD0
21	VFSENSE#	22	SAD1
23	I ² C CLOCK	24	SAD2
25	Key	26	Digital GND
27	Key	28	Key
29	+5V Power	30	SAD3
31	RESET#	32	SAD7
33	SAD6	34	SAD5
35	I ² C DATA	36	REV
37	Audio GND	38	+12V Power
39	Audio Right	40	Audio Left

AGP Connector

(Installation guide reference 8)

<i>Pin</i>	<i>Signal</i>	<i>Pin</i>	<i>Signal</i>
A1	+12V	B1	NOT CONNECTED
A2	NOT CONNECTED	B2	+5.0V
A3	RESERVED	B3	+5.0V
A4	NOT CONNECTED	B4	NOT CONNECTED
A5	GND	B5	GND
A6	INTA#	B6	INTB#
A7	RST#	B7	CLK
A8	GNT#	B8	REQ#
A9	+3.3V	B9	+3.3V
A10	ST1	B10	ST0
A11	NOT CONNECTED	B11	ST2
A12	PIPE#	B12	RBF#
A13	GND	B13	GND
A14	NOT CONNECTED	B14	NOT CONNECTED
A15	SBA1	B15	SBA0
A16	+3.3V	B16	+3.3V
A17	SBA3	B17	SBA2
A18	NOT CONNECTED	B18	SB_STB
A19	GND	B19	GND
A20	SBA5	B20	SBA4
A21	SBA7	B21	SBA6
A22	KEY	B22	KEY
A23	KEY	B23	KEY
A24	KEY	B24	KEY
A25	KEY	B25	KEY
A26	AD30	B26	AD31
A27	AD28	B27	AD29
A28	+3.3V	B28	+3.3V
A29	AD26	B29	AD27
A30	AD24	B30	AD25
A31	GND	B31	GND
A32	NOT CONNECTED	B32	AD_STB1
A33	C/BE3#	B33	AD23
A34	+3.3V	B34	+3.3V
A35	AD22	B35	AD21
A36	AD20	B36	AD19

Pin	Signal	Pin	Signal
A37	GND	B37	GND
A38	AD18	B38	AD17
A39	AD16	B39	C/BE2#
A40	+3.3V	B40	+3.3V
A41	FRAME#	B41	IRDY#
A42	NOT CONNECTED	B42	NOT CONNECTED
A43	GND	B43	GND
A44	NOT CONNECTED	B44	NOT CONNECTED
A45	+3.3V	B45	+3.3V
A46	TRDY#	B46	DEVSEL#
A47	STOP#	B47	+3.3V
A48	PME#	B48	PERR#
A49	GND	B49	GND
A50	PAR	B50	SERR#
A51	AD15	B51	C/BE1#
A52	+3.3V	B52	+3.3V
A53	AD13	B53	AD14
A54	AD11	B54	AD12
A55	GND	B55	GND
A56	AD9	B56	AD10
A57	CBEO#	B57	AD8
A58	+3.3V	B58	+3.3V
A59	NOT CONNECTED	B59	AD_STB0
A60	AD6	B60	AD7
A61	GND	B61	GND
A62	AD4	B62	AD5
A63	AD2	B63	AD3
A64	+3.3V	B64	+3.3V
A65	AD0	B65	AD1
A66	NOT CONNECTED	B66	NOT CONNECTED

NLX Connector (gold fingers)

(Pins marked with an asterisk are defined by the NLX specification but are not connected on the TC440 motherboard)

NLX Riser Connector (Gold fingers) PCI Segment					
Pin	Signal	Terminator	Pin	Signal	Terminator
A1	-12V		B1*	PC_SPKR_RT	
A2	NC		B2	+12V	
A3	+12V		B3	PC_SPKR_LFT	
A4	NC		B4	+12V	
A5	3.3V		B5	PCI_CLK0	MB (series)
A6	INTD#	RISER	B6	GND	
A7	3.3V		B7	PCI_CLK1	MB (series)
A8	INTA#	RISER	B8*	SER_IRQ	
A9	INTB#	RISER	B9	PCI_INT2#	
A10	PCI_CLK2	MB (series)	B10	3.3V	
A11	+3.3V		B11	PCI_CLK3	
A12	PCI_RST#	MB (series)	B12	GND	
A13	PCI_GNT0#	RISER	B13	PCI_GNT3#	
A14*	PCI_CLK4		B14	3.3V	
A15	GND		B15	PCI_GNT2#	
A16	PCI_GNT1#	RISER	B16	PCI_AD31	RISER (series)
A17	3.3V		B17	PCI_REQ0#	
A18	PCI_REQ2#	RISER	B18	GND	
A19	PCI_REQ3#	RISER	B19	PCI_AD29	RISER (series)
A20	PCI_AD30	RISER (series)	B20	PCI_AD28	RISER (series)
A21	GND		B21	PCI_AD26	RISER (series)
A22	PCI_AD25	RISER (series)	B22	3.3V	
A23	PCI_REQ1#	RISER	B23	PCI_AD24	RISER (series)
A24	PCI_AD27	RISER (series)	B24	PCI_CBE3#	
A25	3.3V		B25	PCI_AD22	RISER (series)
A26	PCI_AD23	RISER (series)	B26	GND	
A27	PCI_AD20	RISER (series)	B27	PCI_AD21	RISER (series)
A28	PCI_AD18	RISER (series)	B28	PCI_AD19	RISER (series)
A29	GND		B29	PCI_AD16	RISER (series)
A30	PCI_AD17	RISER (series)	B30	3.3V	
A31	PCI_IRDY#		B31	PCI_CBE2#	
A32	PCI_DEVSEL#		B32	PCI_FRAME#	
A33	3.3V		B33	PCI_TRDY#	
A34	PCI_STOP#		B34	GND	
A35*	PCI_PERR#		B35*	PCI_SDONE	
A36	PCI_SERR#		B36	PCI_LOCK#	
A37	GND		B37*	PCI_SB0#	
A38	PCI_CBE1#		B38	3.3V	
A39	PCI_AD13	RISER (series)	B39	PCI_AD15	RISER (series)

NLX Riser Connector (Gold fingers) PCI Segment					
Pin	Signal	Terminator	Pin	Signal	Terminator
A40	PCI_AD10	RISER (series)	B40	PCI_PAR	
A41	GND		B41	PCI_AD14	RISER (series)
A42	PCI_CBE0#		B42	GND	
A43	PCI_AD0	RISER (series)	B43	PCI_AD11	RISER (series)
A44	PCI_AD6	RISER (series)	B44	PCI_AD12	RISER (series)
A45	3.3V		B45	PCI_AD9	RISER (series)
A46	PCI_AD5	RISER (series)	B46	3.3V	
A47	PCI_AD1	RISER (series)	B47	PCI_AD8	RISER (series)
A48	PCI_AD3	RISER (series)	B48	PCI_AD7	RISER (series)
A49	GND		B49	PCI_AD4	RISER (series)
A50	PCI_AD2	RISER (series)	B50	GND	
A51	+5V		B51	PCI_PME#	MB 10k 3V3SBY

NLX Riser Connector (Gold fingers) ISA Segment					
Pin	Signal	Terminator	Pin	Signal	Terminator
A52	ISA_RSTDRV	MB Series	B52	+5V	
A53	ISA_IOCHK#	MB 4k7 +5V	B53	ISA_IRQ9	MB 10k +5V
A54	ISA_SD6	MB 10k +5V	B54	ISA_DRQ2	MB 5K6 GND
A55	ISA_SD7	MB 10k +5V	B55	ISA_SD3	MB 10k +5V
A56	ISA_SD4	MB 10k +5V	B56	ISA_OWS#	MB 1k +5V
A57	+5V		B57	ISA_SD1	MB 10k +5V
A58	ISA_SD2	MB 10k +5V	B58	ISA_AEN	
A59	ISA_SD5	MB 10k +5V	B59	ISA_IOCHRDY	MB 1k +5V
A60	ISA_SD0	MB 10k +5V	B60	ISA_SA18	MB 10k +5V
A61	ISA_SMEMW#	MB 10k +5V	B61	ISA_SMEMR#	MB 10k +5V
A62	ISA_SA19	MB 10k +5V	B62	ISA_SA16	MB 10k +5V
A63	ISA_IOW#	MB 10k +5V	B63	ISA_IOR#	MB 10k +5V
A64	ISA_SA17	MB 10k +5V	B64	ISA_DRQ3	MB 5k6 +5V
A65	GND		B65	ISA_SA15	MB 10k +5V
A66	ISA_DACK3#		B66	GND	
A67	ISA_SA14	MB 10k +5V	B67	ISA_SA13	MB 10k +5V
A68	ISA_DACK1#		B68	+5V	
A69	ISA_DRQ1	MB 5k6 GND	B69	ISA_REFRESH#	MB 1k +5V
A70	ISA_SA12	MB 10k +5V	B70	ISA_SA11	MB 10k +5V
A71	ISA_SYSClk	MB series	B71	ISA_SA10	MB 10k +5V
A72	ISA_SA9	MB 10k +5V	B72	ISA_IRQ7	MB 10k +5V
A73	+5V		B73	ISA_IRQ6	MB 10k +5V
A74	ISA_IRQ5	MB 10k +5V	B74	ISA_SA8	MB 10k +5V
A75	ISA_SA7	MB 10k +5V	B75	ISA_SA6	MB 10k +5V
A76	ISA_IRQ3	MB 10k +5V	B76	ISA_DACK2#	
A77	ISA_IRQ4	MB 10k +5V	B77	ISA_SA4	MB 10k +5V
A78	ISA_SA5	MB 10k +5V	B78	GND	

NLX Riser Connector (Gold fingers) ISA Segment					
Pin	Signal	Terminator	Pin	Signal	Terminator
A79	ISA_TC		B79	ISA_SA3	MB 10k +5V
A80	ISA_BALE	MB 10k +5V	B80	ISA_SA2	MB 10k +5V
A81	GND		B81	ISA_SA1	MB 10k +5V
A82	CLK14_ISA	MB series	B82	ISA_SA0	MB 10k +5V
A83	ISA_IOC16#	MB 1k +5V	B83	ISA_SBHE#	MB 10k +5V
A84	ISA_MEMCS16#	MB 1k +5V	B84	ISA_LA23	MB 10k +5V
A85	ISA_IRQ11	MB 10k +5V	B85	ISA_LA22	MB 10k +5V
A86	ISA_IRQ10	MB 10k +5V	B86	ISA_LA21	MB 10k +5V
A87	ISA_IRQ15	MB 10k +5V	B87	ISA_LA20	MB 10k +5V
A88	ISA_IRQ12	MB 10k +5V	B88	ISA_LA19	MB 10k +5V
A89	GND		B89	ISA_LA18	MB 10k +5V
A90	ISA_IRQ14	MB 10k +5V	B90	ISA_LA17	MB 10k +5V
A91	ISA_DRQ0	MB 5k6 GND	B91	ISA_DACK0#	
A92	ISA_MEMR#	MB 10k +5V	B92	ISA_DACK5#	
A93	ISA_MEMW#	MB 10k +5V	B93	ISA_SD8	MB 10k +5V
A94	ISA_SD9	MB 10k +5V	B94	ISA_DACK6#	
A95	ISA_DRQ5	MB 5k6 GND	B95	ISA_SD10	MB 10k +5V
A96	ISA_DRQ6	MB 5k6 GND	B96	+5V	
A97	+5V		B97	ISA_SD11	MB 10k +5V
A98	ISA_SD12	MB 10k +5V	B98	ISA_DRQ7	MB 5k6 GND
A99	ISA_DACK7#		B99	ISA_SD13	MB 10k +5V
A100	ISA_SD14	MB 10k +5V	B100	ISA_SD15	MB 10k +5V
A101	ISA_MASTER#	MB 330R +5V	B101	GND	

NLX Riser Connector (Gold fingers) IDE and Floppy Disk Interfaces					
Pin	Signal	Terminator	Pin	Signal	Terminator
A102	PIDE_D8	MB series 33R	B102	GND	
A103	PIDE_RESET#	MB series 33R	B103	PIDE_D7	MB series 33R
A104	PIDE_D9	MB series 33R	B104	PIDE_D6	MB series 33R
A105	+5V		B105	PIDE_D5	MB series 33R
A106	PIDE_D4	MB series 33R	B106	PIDE_D11	MB series 33R
A107	PIDE_D10	MB series 33R	B107	PIDE_D12	MB series 33R
A108	PIDE_D3	MB series 33R	B108	GND	
A109	PIDE_D13	MB series 33R	B109	PIDE_D14	MB series 33R
A110	PIDE_D1	MB series 33R	B110	PIDE_D2	MB series 33R
A111	GND		B111	PIDE_D0	MB series 33R
A112	PIDE_IOW#	MB series 33R	B112	PIDE_D15	MB series 33R
A113	PIDE_DREQ	MB series 82R	B113	PIDE_IOR#	MB series 33R
A114	PIDE_RDY	MB series 82R	B114	PCSEL	470R GND
A115	PIDE_DACK#	MB series 33R	B115	ISA_IRQ14	MB series 82R

NLX Riser Connector (Gold fingers) IDE and Floppy Disk Interfaces					
Pin	Signal	Terminator	Pin	Signal	Terminator
A116*	RSVD1		B116	+5V	
A117	PIDE_DA2	MB series 33R	B117	PIDE_DA1	MB series 33R
A118	PIDE_CS1#	MB series 33R	B118	PIDE_DA0	MB series 33R
A119	+5V		B119	PIDE_CS3#	MB series 33R
A120*	PDASP#		B120	SIDE_D8	MB series 33R
A121	SIDE_RESET#	MB series 33R	B121	SIDE_D7	MB 33R series
A122	SIDE_D9	MB series 33R	B122	GND	
A123	SIDE_D6	MB series 33R	B123	SIDE_D10	MB series 33R
A124	SIDE_D5	MB series 33R	B124	+5V	
A125	SIDE_D11	MB series 33R	B125	SIDE_D4	MB series 33R
A126	SIDE_D12	MB series 33R	B126	SIDE_D3	MB series 33R
A127	GND		B127	SIDE_D13	MB series 33R
A128	SIDE_D2	MB series 33R	B128	SIDE_D14	MB series 33R
A129	SIDE_D15	MB series 33R	B129	SIDE_D1	MB series 33R
A130	SIDE_IOW#	MB series 33R	B130	SIDE_D0	MB series 33R
A131	SIDE_DREQ	MB series 82R	B131	SIDE_IOR#	MB series 33R
A132	SIDE_RDY	MB series 82R	B132	SCSEL	470R GND
A133	GND		B133	ISA_IRQ15	MB series 82R
A134	SIDE_DACK#	MB series 33R	B134	SIDE_DA1	MB series 33R
A135*	NC		B135	SIDE_DA2	MB series 33R
A136	SIDE_DA0	MB series 33R	B136	SIDE_CS3#	MB series 33R
A137	SIDE_CS1#	MB series 33R	B137*	SDASP#	
A138*	DRV2#		B138	GND	
A139	+5V		B139	FD_DRATE0	
A140*	NC		B140	FD_DSEL1#	
A141	FD_DENSEL		B141	FD_DSEL0#	
A142	FD_MOT0#		B142	FD_DIR#	
A143	FD_INDEX#		B143*	MSEN1	
A144	FD_MOT1#	MB 10k	B144	GND	
A145	GND		B145	FD_WDATA#	
A146	FD_WGATE#		B146	FD_TRK0#	
A147	FD_STEP#		B147*	MSEN0	
A148	FD_WPRT#		B148	FD_RDATA#	
A149	FD_HDSEL#		B149	FD_DCHG#	

NLX Riser Connector (Gold fingers) Miscellaneous					
Pin	Signal	Terminator	Pin	Signal	Terminator
A150	SMBUS_DATA	MB 2K7 +3V3	B150	GND	
A151	SMBUS_CLK	MB 2K7 +3V3	B151*	IRSL0	
A152	FANTACH1	MB 10K +12V	B152*	IRSL1	
A153	FANTACH2	MB 10K +12V	B153*	IRSL2	

A154	FANTACH3		B154	IO_IRTX	
A155	IO_FANCTL		B155	IO_IRRX	MB 10K +5V
A156	+5V		B156*	FPSLEEP	
A157	NLX_USBP1-		B157	FPRST#	
A158	NLX_USBP1+		B158	GND	
A159	PIIX_SBOC1#		B159	STANBY_LED #	
A160*	USB2N		B160	PSU_PWRGOOD	
A161*	USB2P		B161	COR_SBYBTN #	
A162*	USB2OC#		B162	PSU_ON#	
A163	GND		B163	LAN_WAKE	
A164	VBATNLX		B164*	LANLED	
A165	INTRUDE#	MB 1M (VBAT)	B165*	MDMWAKE#	
A166	MSG_LED#		B166*	1394PWR	
A167*	1394GND		B167*	RSVD7	
A168*	RSVD4		B168*	RSVD6	
A169	5VSBY		B169*	RSVD5	
A170	+3V3 (SENSE)		B170*	-5V	

NLX Supplemental Connector			
X1	CD IN LEFT	Y1	CD IN RIGHT
X2	AUDIO GND	Y2	AGND
X3	MIC IN	Y3	AUDIO 5V
X4	HEADPHONE OUT LEFT	Y4	HEADPHONE OUT RIGHT
X5	HEADPHONE SWITCH	Y5	MICROPHONE SWITCH
X6	VOL_DN#	Y6	VOL_UP#
X7	GND	Y7	NC
X8	NC	Y8	NC
X9	NC	Y9	GND
X10	NC	Y10	NC
X11	NC	Y11	NC
X12	AGND	Y12	NC
X13	MODEM MIC	Y13	MODEM SPEAKER